

VISSONIC

Professional Audio Video Manufacturer

Audio Product & Audio-Link Solutions

Product Datasheet



VISSONIC ELECTRONICS LTD.

Think Solution

Application diagram

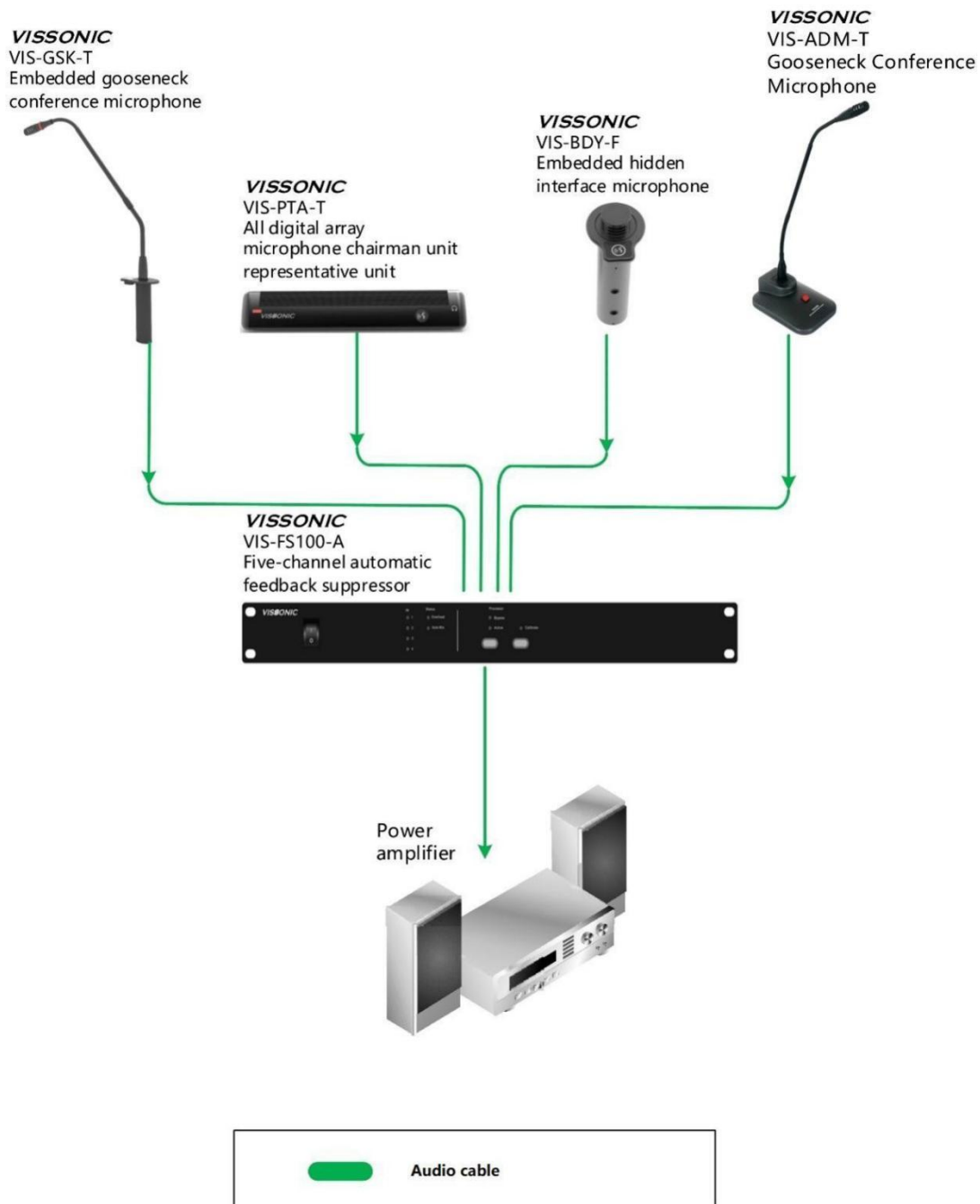

AUDIO LINK Products

VIS-AIB

Microphone interface box

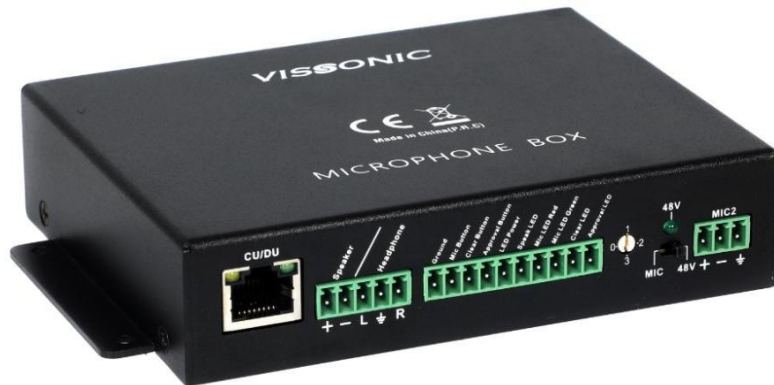

The VIS-AIB microphone interface box is designed to support VISSONIC conference microphone remotely installed under the table or armrest solution. With the phoenix connectors on both sides of the box, it can connect Dynamic mic/Boundary Condenser mic input, buttons and speakers on plate to control the conference unit etc. By the RJ45 port it can easily connect into existing VISSONIC conference microphone family to integrated into one part seamlessly.

It's an ideal solution for customized operation plate on the table and hide the main part of microphone, or any analog microphone like wired handheld type into the same system.

Features

- Compact metal cover design to mount under table or armrest of chair.
- VIS-AIB Microphone interface box is suitable for customized installation solutions. It allows to add a variety of functions to meet meeting needs. In addition, two separate audio inputs are provided, each with or without phantom power microphone, such as capacitor type or dynamic type.
- It also provides microphone switch button, priority button, approval button and corresponding LED light Phoenix interface, which is used to customize embedded button panel for gooseneck microphone.
- Adjustable sensitivity, compatible with different inputs
- RJ45 port to connect into VISSONIC networked system seamlessly
- It provides two phoenix stereo jacks for connecting to headphones, and two speaker outputs for connecting to speaker panels (VIS-SPK-F) or custom speakers.

Technical Parameters

Voltage supply 48V DC

Static power consumption 1W Frequency Response 20Hz ~ 20KHz

Noise ratio (S / N) > 80dB

Page 2

Total harmonic distortion <0.05% Channel Crosstalk> 80dB

Dimensions (mm) 120L x 100W x30H with two ears for screw fix Color: Black

Weight: 0.5KG

Wiring Connections

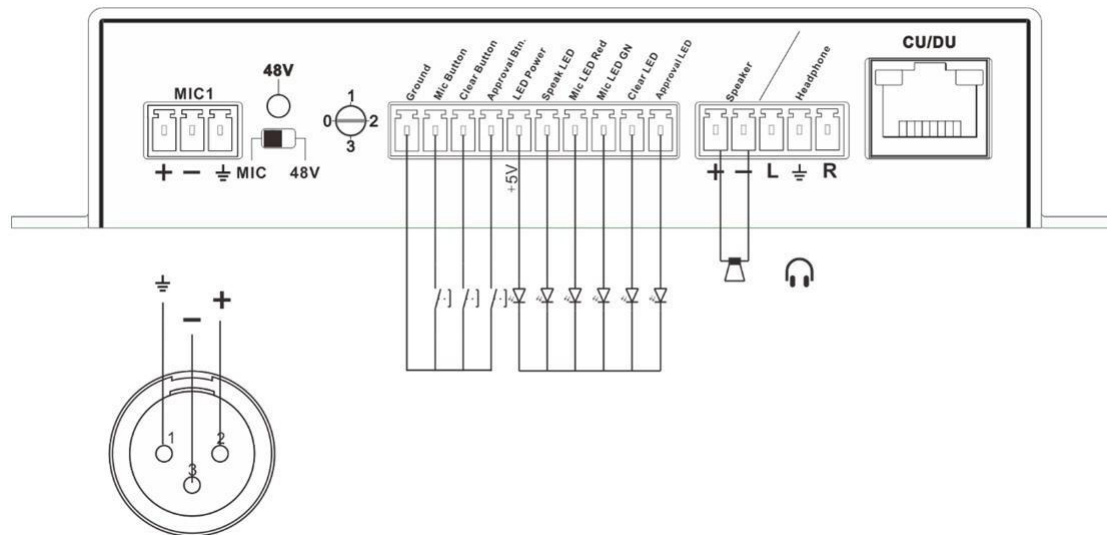

Connectors

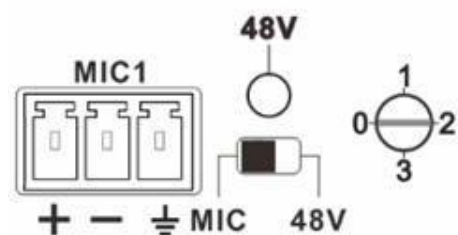

2xRJ45 port

2xBoundary condenser mic phoenix connector

2xSwitch for MIC/48V option

2xGain adjust knob

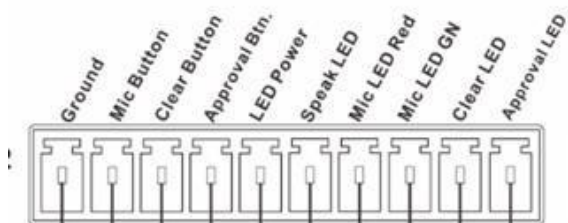

2x Group phoenix connectors including: Ground

Mic button for microphone ON/OFF

Clear button for chairman priority operation

Approval Button for chairman priority operation

LED Power: +5 V, max. 40 mA

Speak LED indicate the gooseneck light color

Page 3

Mic LED red indicate the microphone is ON of the conference unit

Mic LED green indicate the microphone is in request-to-speak mode of the conference unit

Clear LED shows the chairman is in priory mode to mute or close the delegate

Approval LED shows the chairman operating approval to speak

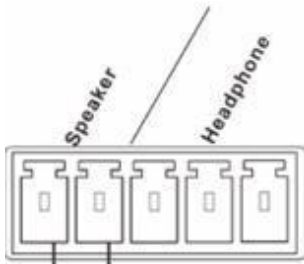

2x 5 pin phoenix connector for speaker and headphone

Headphone Output independence: 16 Ω

Speaker output independence: 8 Ω

Frequency response: 20~15000hz

VIS-DCP2000-R

Full Digital Networked DSP Conference Processor for Array mic



Features

- The unique AUDIO-LINK digital ring network technology achieve full-digital signal transmission and processing.
- Single CAT5e cable transmits 64 channels of audio and various information.
- All microphone units support audio, ID independent output. Working with voice recognition system to achieve voice role separation.
- High-fidelity sound quality, lossless audio transmission technology, 48K audio sampling frequency, 20Hz ~ 20KHz response frequency.
- A single conference controller can realize the independent control and merging of 4 conference rooms, can handle the cascade of multiple conference controllers to realize the merging and separation of larger conference rooms (including conference management, etc.).
- "Hand-in-Hand-Loop-Network" connection makes the system always working perfectly no matter changing discussion unit or having any malfunctioned units.
- The sensitivity of the unit microphone and 8 segment equalizer EQ adjusted independently.
- The main controller comes with self-learning AFC automatic feedback algorithm, combined with array microphones, short-stem microphones to achieve ultra-long pickup distance.
- Support AGC (Automatic Gain Control)/AFC (Adaptive Feedback Cancellation)/ANC (Acoustics Noise Cancellation) Sound output by separated zones function, each zone is automatically adjusted according to the volume of the position of the microphone, achieve longer distances pickup without whistle.
- Echo cancellation, remote two-way real-time call with another conference controller or another third-party video conferencing terminal.
- USB recording, controller monitor, advanced noise cancellation technology to realize clearer recording.
- Display with date, time management, and support speech time, countdown speech.
- Optional DANTE output module with other DANTE equipment used.
- Can drive 2*120W POE speaker through extension main unit, support up to 16 POE speakers.

Functions

- Compliance with IEC 60914, GBT 15381-94.
- Connect with VIS-EXM extension main unit, it can expand to 5200 discussion units.

- "Hand-in-Hand-Loop-Network" connection and the system assigned to each unit independently ID to avoid ID conflict.
- Both wired/wireless discussion units can connect to the controller, fast and easily to adding delegate of meetings.
- Supports up to 8 wireless microphones to be turned on at the same time, adaptive avoiding interference technology to achieve stronger anti-interference ability, compliance with IEEE 802.11n standard Wi-Fi both for 2.4GHz and 5GHz.
- 2 channel audio input, XLR or RCA type, for local audio input or remote video-conferencing input.
- Maximum 8-channel audio output, XLR, RCA or Phoenix type, can be connected to simultaneous interpretation output or partitioned output.
- Add the audio input box, the system can be connected to other condenser microphones or dynamic microphones, more choices for users.
- Built-in multi-way internal communication function.
- TCP/IP connection between controller and PC
- RS232 central control, realize microphone switch, priority, volume and other controls.
- RS232 or RS485 to send the PELCO/VISCA protocol to realize camera auto-tracking function.
- Hot plug-and-play, and auto-recovery function.
- Wide range of voltage from 100V~240VAC
- Without using PC software, our conference controller still owns following settings:
 - Limit on the number of speaking persons: By Setting the number of active units at the same time (Number is 1/2/4/6/ units), supports up to open 32 wired microphones in full-on mode.
 - Discussion modes:
"OPEN" Free for all, limited by the active units setting by controller, "VOICE" Can activate MIC by detecting sound without press button, "OVERRIDE" First in First out, "APPLY" To apply then to speak, "PTT" Press to speak (Optional), "ALL" Full open mode (Optional).
 - Limit on the number of speaking persons: By Setting the number of active units at the same time (Number is 1/2/4/6/ units), supports up to open 32 wired microphones in full-on mode.
 - Discussion modes:
"OPEN" Free for all, limited by the active units setting by controller, "VOICE" Can activate MIC by detecting sound without press button, "OVERRIDE" First in First out, "APPLY" To apply then to speak, "PTT" Press to speak (Optional), "ALL" Full open mode (Optional).
 - Voting function: Approve/Abstain/Object
 - Chairman unit has priority to close all other units or mute them temporarily
 - Chairman unit can approval the application for speaking from delegate
 - Simultaneous language interpretation
- With PC software to add more ways of voting:
 - Approve/Object
 - Approve/Abstain/Object
 - Level: 1/2/3/4/5
 - Ranking: --/0/+/++
- By using RFID card to identify, can realize voting with names.

Control & Indicators

LCD display to show all the operations and results

4-Way button for menu operate

One-button press to start recording

Recording light indicator

Master volume control knob

Interfaces

Front panel USB recording port

3.5mm headphone for monitoring

1x RCA audio input

1x XLR audio input

1x RCA audio output

1x XLR audio output

6x Phoenix connector audio output

2x RJ45 digital audio connection

2x RJ45 for chairman unit, delegate unit, unit translators and other connection

1x RJ45 for wireless AP or router

1x DP9 male port for external control

1x DP9 female port for camera

1x three-pin phoenix connector for camera control keyboard

1x RJ45 for computer connection or network switcher

1x grounding screw

1x 100 ~ 240V DC Power Interface

Technical Parameters

Power 100V / 240V AC

Static power consumption 12W

Maximum power consumption 150W

Frequency Response 20Hz ~ 20KHz

Noise ratio (S / N) >96dBA

Total harmonic distortion <0.05%

Channel Crosstalk > 85dB

Dynamic range >94dB

RS-232 control: 1×9-pole Sub-D female socket 1×9-pole Sub-D male socket

Ethernet control: RJ45 connected to PC

Mounting: 19" standard rack

Dimensions (mm) 481L x 265W x46H

Weight: 3kg

Black color

Max. audio inputs

LINE IN 1: +10dBu

LINE IN 2: +10dBu

Max. audio outputs

Page 7

LINE OUT 1: +12dBu BAL.

LINE OUT 2: +12dBu BAL.

LINE OUT 3: +12dBu BAL.

LINE OUT 4: +12dBu BAL.

Transmission technology: WIFI 802.1n

Encryption technology: WPA2-PSK AES

Working frequency: 5.2-5.8 GHZ

Output impedance: >1kΩ

PC communication method: TCP/IP

Camera control method: RS-232/UDP

Network Interface: RJ45

Display: LCD1602

Limit on the number of speakers: 1/2/4, max in 6 persons

Camera Tracking Protocol: PELCO-P/PELCO-D/VISCA

Operating temperature: 0 ~ 45°C

Storage temperature: 20 ~ 50°C

VIS-PTA-T

Analog Array Microphone Unit



The SONICON series array microphones designed by VISSONIC adopt the ARRA-Tech™ array microphone technology independently developed. The sound pickup distance is not less than 80CM. The corridor-type directional characteristics increase the acoustic transmission gain. The use of hidden microphones makes the conference room cleaner. The array microphone maintains a clear and stable pickup function, increasing the speaker's range of activity.

Features

- Unique modern design with touch button.
- Using the self-developed ARRA-Tech™ array microphone technology,
- The pickup distance is 60-80CM. The establishment of a personal pick-up sound area, whether the speaker is standing, backward or sideways, provide freely speaking experience.
- With no goose neck design, speakers and attendees can communicate without blocking the view.
- The hidden adjustable gain knob can quickly set up the whole system according to the field sound amplification conditions.
- 2m audio cable with XLR male connector for extending to the VISSONIC dB-NET series DSP audio matrix or any mixer system.

Technical Specification

Microphone.....	Microphone Array
Polar pattern.....	Corridor
Control.....	Touch button for on/off
Frequency response.....	30 - 18,000 Hz
Optimal distance of the speaker.....	60 - 80 cm
Open circuit voltage at 1 kHz	approx. 200 mV/Pa
Output level with selector.....	0dB,-5dB,-10dB or -20dB
Nominal impedance.....	200 Ω
Load impedance.....	> 1 kΩ
S/N ratio rel. to 1 Pa.....	60 dB
T.H.D.....	< 0.1%
Voltage supply.....	Phantom powering 48 V ±4 V to 6.8 kΩ
supply impedance 24 V ±4 V to 1.2 kΩ	supply impedance

Power consumption.....11 mA*

Connection.....3 pins XLR

Item Model for Order

VIS-PTA-T.....Array Microphone with XLR connector

VIS-FS100-A.....5 channel automatic feedback suppressor with Audiolink port

VIS-DSP8/12/16.....DSP audio processor

CLEACON VIS-BDY-F

CAT5 Wired Digital Discussion Unit with physical button



VIS-BDY-F is a built-in microphone that makes the microphone hide on the desktop when not in use. This is achieved by simply pressing down on the top of the microphone until it locks. Then press the microphone again, and the microphone will rise back to its original position. This microphone can be used in the CLEACON Full-digital network conference system through the VIS-AIB analog connection box, or it can be used in the analog system, such as VIS-FS100-A automatic feedback suppressor, mixer, audio processor, etc.

Features

- Low profile on any desktop or surface
- The microphone is equipped with a reed switch, which is designed to switch at the beginning and end of each session when the microphone is no longer used. When the microphone is in the up position, the switch contact is closed (ON), and when it is retracted, the switch will be OFF.
- Capacitive touch button can be optionally installed to easily set the microphone off or on for sound pickup.
- Cardioid pattern.
- Built-in microphone preamp power supply module, no need to use external power supply module
- The sturdy all-metal structure design provides two layers of steel mesh cover protection
- The microphone works from DC 11V to 52V phantom power.
- Output with 3-pin XLR or 3.5 Phoenix connector
- Built-in ring-shaped LED status indicator
- Built-in RF filter
- Equipped with shock-proof isolators to reduce vibration noise on the installation surface

Specification

- Mic capsule.....electrostatic capacitive type
- Directivity Pattern.....Cardioid

- Frequency response..... 40-19,000 Hz
- Turn-on sensitivity -40 dB (10 mV) at 1V at 1 Pa Impedance 200 ohm
- High maximum.....SPL 142 dB SPL, 1 kHz at 3% T.H.D.
- Dynamic range.....(typical) 113 dB, 1 kHz at highest sound pressure level
- S / N.....65 dB, 1 kHz at 1 Pa
- Phantom power.....DC 11-52V, power consumption 5.7 mA typical
- Switch Touch control.....On / Mute
- Weight.....65 g
- Overall.....length 84.8 mm, diameter 38.0 mm, maximum width 48.0 mm
- Output terminal.....Built-in 3-pin XLR
- Standard configuration.....1 pair of shock-proof isolator

Product Dimension

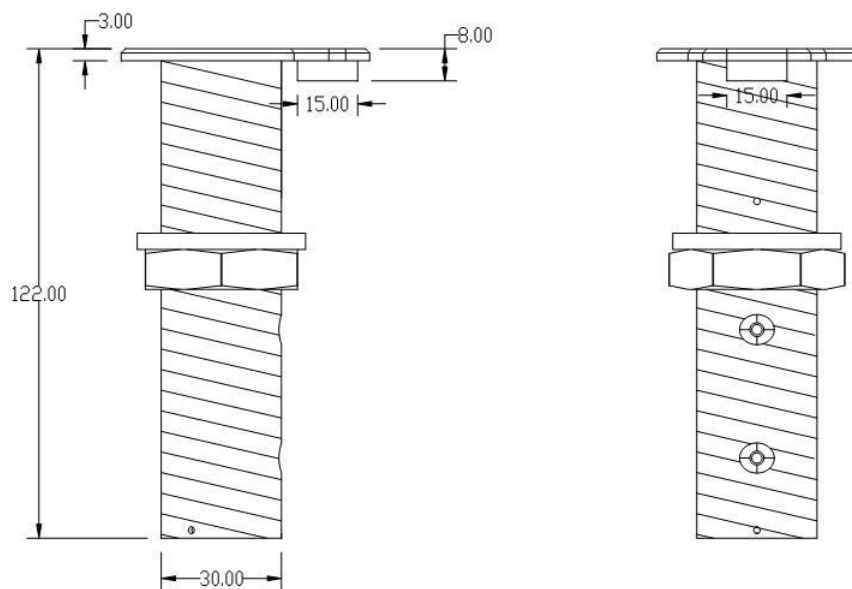
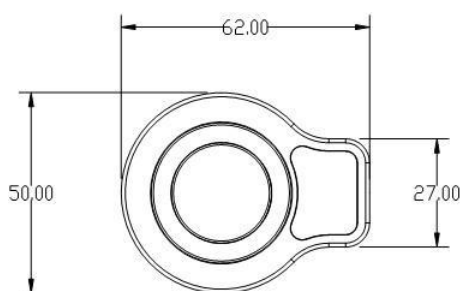

Item Model for Order

VISVIS-BDY-F..... Flush mount boundary Microphone

VIS-AIB..... Analog microphone connection box

VIS-DCP2000-D..... Full Digital Network DSP Conference System Controller

VIS-FS100-A..... Fully automatic feedback suppressor



VIS-GSK-F

Flush Mount Microphone Base



VIS-GSK-F is a flush mount gooseneck microphone base that can be connected to all range of VISSONIC M series microphones, the microphone can be removed from the base when it's not in use. The overall base is small and exquisite, with a touch button to switch the microphone on and off. It can be connected to the VIS-AIB analog microphone connection box and used in the CLEACON conference system, or it can connect to an analog system, such as the VIS-FS100-A automatic feedback suppressor, mixer, audio processor etc.

Features

- Built-in microphone socket, suitable for VIS-M series 6-pin gooseneck microphone
- It is used for inconspicuous installation on the desktop with compact design.
- Capacitive touch switch button can be optionally installed to easily set the microphone off or on for sound pickup. The built-in switch can be used for control from remote equipment.
- Touch button comes with LED status light, operates with phantom power, provides white / red two colors
- Operation with 24-48V phantom power
- Output with 3-pin XLR or 3.5 Phoenix connector
- After inserting the microphone in place, the microphone comes with fasten lock, and the microphone can only be removed after unlock it
- Built-in RF filter
- Equipped with rubber isolators to reduce vibration noise on the installation surface

Specification

Output impedance: 360 Ω

Control

High level when in down position: (DC + 5V);

Low level when in up position: (DC 0V)

LED indicator

High electric level DC + 5V): red /

Low electric level (DC 0V): white

Phantom power

DC: 24-48V,

Power Consumption: 4 mA typical

Switch

Touch control Weight: 65 g

Dimensions: length 128.2 mm, maximum width 55.3 mm

Accessories

One set of metal fixing ring for standard installation, one pair of shockproof isolators

Open hole dimension

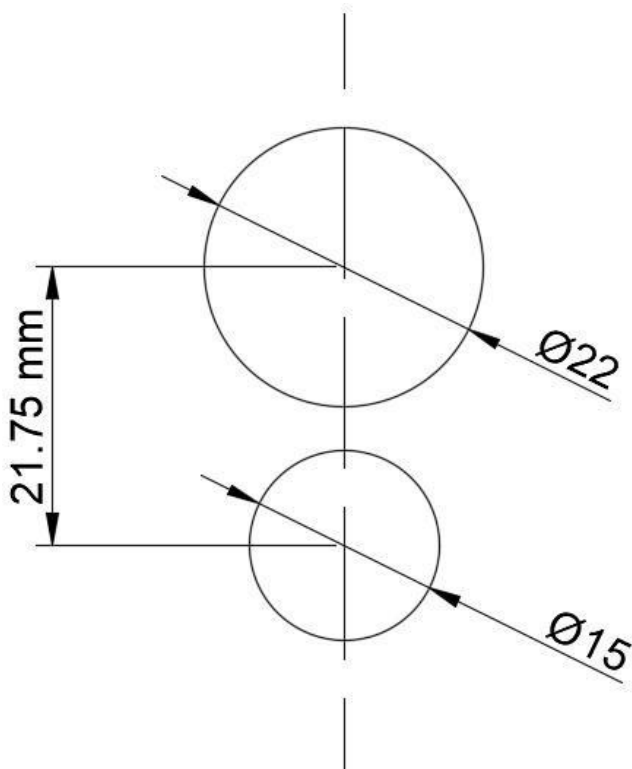

Dimension:

Diameter of the microphone body: 22mm

Touch button diameter: 15mm

The distance between the main body and the button center: 21.75mm

Product Dimension

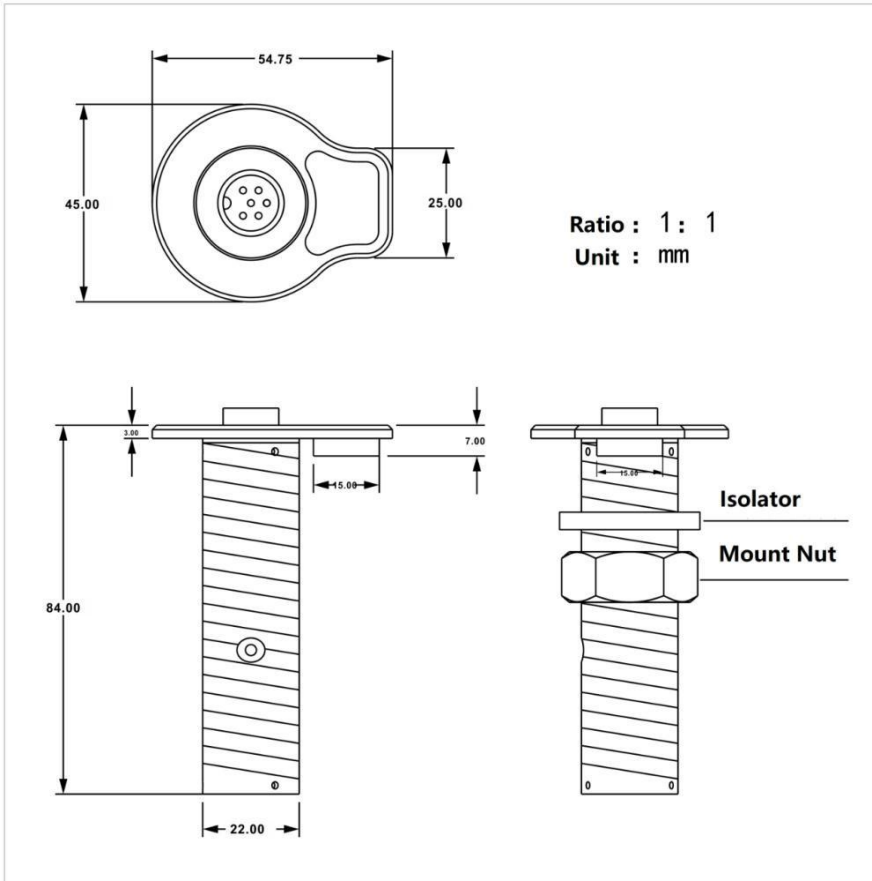

Item Model for Order

- VIS-GSK-F.....Flush mount Gooseneck Microphone Base
- VIS-MDA.....Rectangular metal microphone
- VIS-M220.....220mm microphone (black) with anti-wind foam cover
- VIS-M330.....330mm microphone (black) with anti-wind foam cover
- VIS-M410.....410mm microphone (black) with anti-wind foam cover
- VIS-M485.....485mm microphone (black) with anti-wind foam cover
- VIS-M600.....600mm microphone (black) with anti-wind foam cover
- VIS-AIB.....Analog microphone connection box
- VIS-DCP2000-D.....All Digital Network DSP Conference System controller
- VIS-FS100-A.....Fully automatic feedback suppressor

CLEACON VIS-CIB

Full digital interface box



Features

- The full-digital interface box is a conference product specially designed to meet the special needs of the conference. The exterior is mini and lightweight, and the all-metal thin shell design can cope with any environment and can be easily installed under the table and table. Indirect seams or armrests can be connected to the VISSONIC hand microphone for conference environments without a conference table. Or when there is a need to customize a dedicated conference panel or a panel with special features, VIS-CIB can meet the diverse needs of customers.
- Built-in DSP digital sound processor, 48kHz High-quality sound sampling frequency for AGC function of the picked-up audio for devices such as gooseneck microphones on connected panels or handheld microphones. At the same time, it also has ANC function to filter out the noisy background audio in the conference space. Through the AFC function, the feedback problem can be processed effectively and quickly, avoiding the whistling of the microphone and affecting the quality of the conference. And can transmit high-definition lossless digital audio through digital audio processing technology
- All-in-one interface box with chairman and delegate switching function, only need to connect with the conference controller, and quickly and easily switch the device function settings directly from the controller menu, without using the computer, through the web program or It is a software setting.
- Ability to use the Cat5e cable with all VIS-DCP2000 full-digital conference controller and conference device are connected to each other and support hot-swap function. Users can join or remove the conference device at any time during the conference according to the needs of the conference, and will not affect any microphone in the conference
- With digital ID configuration function, users can customize the representative ID address of the conference device before the conference by extending the external customized panel according to the needs of the conference, which can be used for sound group distribution and external output, or the conference microphone is used for the automatic tracking of the speaker image.
- When using an extended external custom panel, the VIS-CIB provides the following features:
 - The plug-in gooseneck microphone dual-color display function can display the speech or wait for the speech status.

- For the panel of the chairman function: Provide the chairman function switch to turn off the delegate function.
- When it is a panel of the function: Provide speaking switch.
- Provides speaker output function, which can be used to selectively set the conference system loudspeakers on the panel.
- Supports the speaking timing function, which automatically turns off the microphone when the speaking time is cut off.
- The conference microphone function can be activated by voice control through the voice of the speaker.

Specification

Maximum power consumption.....2.0W
Frequency response.....20~20kHz
Total Harmonic Distortion (THD).....<0.1%
Dynamic range.....>94dB
Signal to noise ratio (S/N).....>96dB
Rated microphone input.....>70dB SPL
Maximum microphone input.....>100dB SPL
Speaker rated output.....>70dB SPL at 0.5m
Sensitivity.....-46 dBV/Pa

Connect:

RJ-45 female seat.....2
D-Sub 15 Pin.....1
Color.....Black
Weight.....300g
size (mm).....100L x 60W x 24 H

CLEACON VIS-HM100

Handheld Microphone



The VIS-HM100 is a handheld conference microphone for the CLEACON system. The microphone is designed for the CLEACON series of conference units VIS-CIB. Applications for this microphone include a pressroom where the speaker needs to stand up, an auditorium, etc., or where the microphone must be hidden when not in use. The microphone features a low-noise condenser core design for clear speech and reduced feedback through a cardioid directional mode. The mic core is acoustically and mechanically isolated to prevent the microphone from picking up mechanical noise from the table. There is a large illuminated ring on the microphone that indicates when the microphone is turned on. The switch is used to turn the microphone on/off or to add a unit to the request queue. The microphone is supplied with a professional 6-pin XLR plug for use with spiral or straight cable.

Features

- LED ring indicator
- Heart-shaped pickup
- Rear electret condenser pickup
- Double rubber suspension pickup
- Highly close SPL level
- Low noise pickup
- Dual function switch
- Two-color LED

Specification

Pickup head.....Back-electret condenser
 Frequency response.....50Hz~18kHz
 Power consumption.....1.5 to 9 VDC
 Dynamic range.....>94dB
 Signal to noise ratio (S / N).....<60 dBA
 Maximum microphone input.....> 138 dB SPL
 THD.....<0.1%
 Speaker rated output.....> 70dB SPL at 0.5m
 Sensitivity.....-68 dB±3dB /μBar
 Impedance.....2 kOhms @ 1 kHz

connection:
 Mechanical connector..... 6-pin XLR male
 Color:
 Black Weight.....0.2kg
 Dimensions (height x diameter).....160 x 30mm

How to Order

Handheld microphone. With speak request button and light ring.
 VIS-HM100 2m 6-pin XLR-f to 15HD-sub-m spiral cable.
 VIS-HMC-02 3m 6-pin XLR-f to 15HD-sub-m spiral cable. VIS-HMC-03

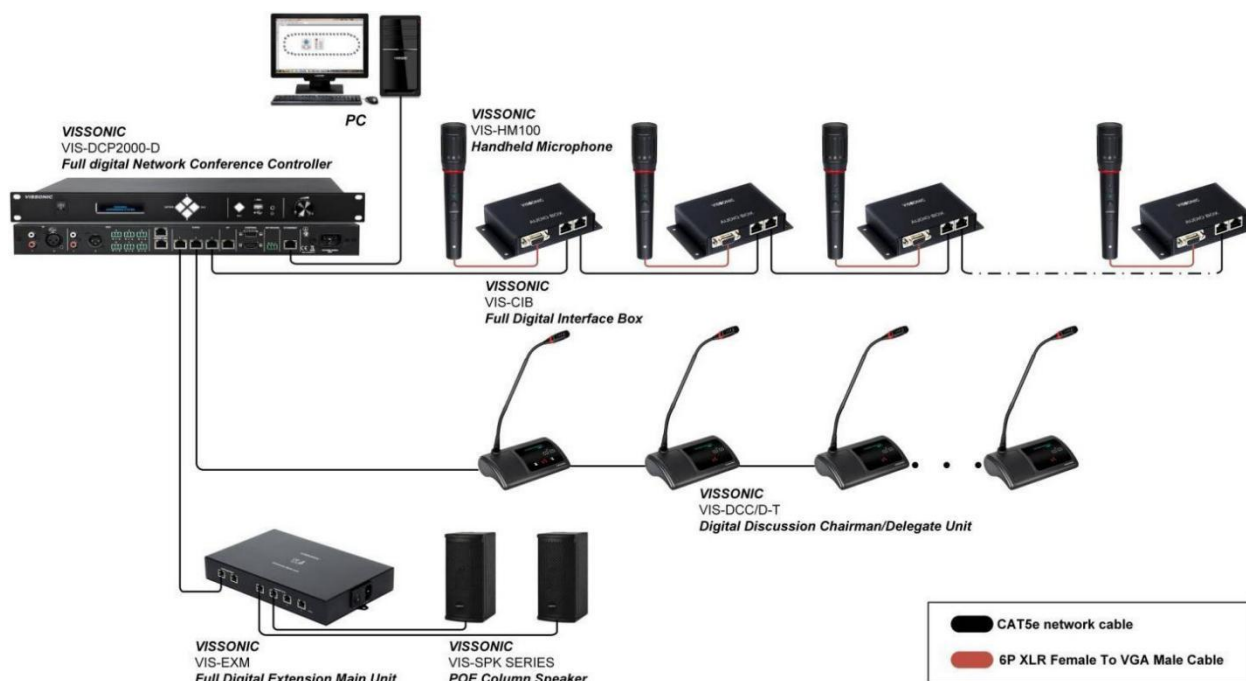

VIS-FS100-A

Automatic feedback suppressor



VIS-FS100-A feedback suppressor uses a powerful signal processor and a fully automatic adaptive algorithm, which is easy to use. In addition to supporting 4-line / microphone input, it is also equipped with an AUDIOLINK digital audio cascade interface and supports 5 channel automatic mixer.

Features

- Fully automatic high-speed howling suppression algorithm, no need to debug, ready to use
- Eliminate feedback
- Automatically adapt to the acoustic environment
- Up to 12DB additional gain to effectively prevent feedback
- Equalized line or microphone input to provide phantom power
- With AUDIOLINK digital cascade input and output interface
- Four microphone inputs and digital interface AUDIOLINK inputs with automatic mixer

Function

- The adaptive filter can switch between "Fast" mode and "Precise" mode. Fast mode is suitable for situations where the microphone position changes frequently. Adaptive filters converge at a slower rate, suppressing more reverberation components. Depending on the acoustic environment and the selected operating mode, an additional gain of up to 12DB can be obtained before acoustic feedback occurs.
- The feedback suppressor also has a built-in automatic mixer to achieve four microphone inputs. In many cases, such as on a podium, pulpit, or conference table, the use of the above two microphones can better capture the voice of a moving speaker, which often increases the risk of acoustic feedback. In view of this problem, the automatic mixer in the feedback suppressor will automatically reduce the gain of the microphone with a weak signal input, while increasing the gain of another microphone with a strong signal input. In this way, it can track the speaker on the move, producing the best sound clarity. At the same time, since the total amount of gain remains constant, a maximum volume is maintained without generating acoustic feedback.
- When the feedback suppressor is configured with two AUDIOLINK cascade interfaces, it is connected to the CLEACON series conference controller through the AUDIOLINK interface, and the conference controller outputs audio to the feedback suppressor for mixing output, and can be cascaded to the next feedback suppressor or Other devices with AUDIOLINK interface.
- Even if the feedback suppressor is switched to the "bypass" mode, the automatic mixer function still works.

Controls and indicators

- Switch
- Bypass button with yellow LED
- Activate ACTIVE button with yellow LED
 - Calibration button. Start quick calibration cycle
- 4-channel microphone / line input status indicator
 - Overload (at 0DBFS), red LED
 - Enable Auto Mix, yellow LED
 - Calibration, yellow LED

Specification

Electrical characteristics

Power supply voltage.....230VAC / 115VAC, ± 10%, 50 / 60Hz
15W
Maximum starting power.....1.5A (230VAC) / 3A (115VAC)
Sampling rate.....32KHZ
Frequency response.....125HZ-15KHZ, <1% at 1KHZ distortion
Gain.....0dB line in, 12dB / 0dB / -12dB (Low / Med / High) microphone input
Gain adjustment range.....Mute ~ 20dB
S / N ratio.....> 90DB
Signal delay.....<11 ms
Decoupler frequency variation.....up to 5HZ shielding noise

Line / microphone input

Maximum input level.....dBv
Output resistance.....<100 ohm
CMRR.....> 25DB (50HZ-20KHZ)
24V phantom power (microphone only, switchable)
10dBv maximum output level

Conventional

Relative temperature..... <95%
Weight3 kg
Operating temperature range..... from 10 ° C to 55 ° C
Storage temperature range40 ° C to 70 ° C
Relative humidity<95%

Item Model for Order

VIS-FS100-A.....Five-channel Fully Automatic Feedback Suppressor
VIS-FS100.....Four-channel full-automatic feedback suppressor

VIS-DSP8/DSP12/DSP16

dB-NET series Digital DSP Audio Matrix

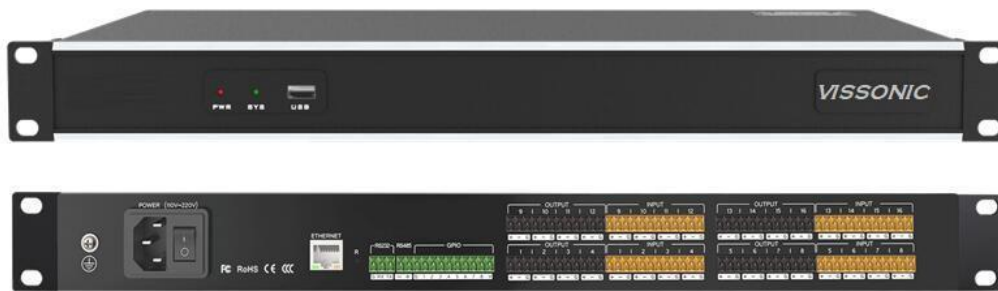

Features

- 8,12,16 CH balanced microphone input, using the phoenix plug
- 8,12,16 CH balanced microphone output, using the phoenix plug
- A variety of audio formats in front panel can extend the USB multimedia storage for recording.
- Can control by PC, mobile phone, tablet, web, key panel, Control system and so on
- Main algorithms, such as built-in signal generator, auto mixing, feedback suppressor, echo cancellation, noise cancellation(optional) etc.
- Input per channel: preamplifier, signal generator, expander, compressor,5 parameters of equilibrium.
- Output per channel: 31 segment graphic equalization, delay, divider, limiter
- Full functional matrix mixing, with the built-in patented component matrix adjustment function.
- Built-in automatic video tracking function, easy to implement video conferencing, support scene presupposition function, power automatic protection memory function
- There are more than dozens of professional audio processing modules, such as: 5-band full parametric equalizer, 31-band graphic equalizer, high-precision compression and limiter, high-sensitive expansion and automatic gain, crossover, automatic mixing Amplifier, delayer, matrix mixer, component matrix adjuster, noise threshold, mute module, signal generator and signal indicator level meter, etc.
- The built-in media control code generator does not require the self application formula to edit the code.
- The equipment provides a universal programmable I/O port and sets firefighting functions.
- RS-232 bidirectional serial control interface; it can control other external devices such as video matrix, video camera and other RS-232 devices, or receive third party RS-232 control
- The phantom power supply (each input) +48 VDC10mA.

Specification

Performance parameter

Number of analog channels.....8 channels input + 8 channels output (DSP8), 12 channels input + 12 channels output (DSP12), 16 channels input + 16 channels Output (DSP16)

Core algorithm.....automatic mixing, feedback cancellation, echo cancellation

GPIO.....nput and output share 8

RS232/RS485.....1

RJ45 control interface.....1

USB interface.....1

Simulated maximum gain.....51dB
Sampling rate.....48K
Frequency response (20~20KHz).....±0.2dB
A/D dynamic range (A-weighting)114dB
Digital/analog dynamic range (A-weighting)120dB
Input to output dynamic range.....108dB
Total harmonic distortion + noise.....<0.002% @1KHz ,4dBu
Noise floor (A-weighting).....90dBu
Delayed storage.....2s
Analog input to analog output system delay.....3ms
Input impedance (balanced).....20KΩ
Output impedance (balanced).....100Ω
Maximum input level.....+24dBu, balanced
Maximum output level.....+24dBu, balanced
Equivalent input noise EIN (20-20kHz, A weighting).....≤-131dBu
Phantom power (per input).....V
Input common mode rejection, 60Hz.....80dB
Channel isolation, 1kHz.....100dB
Power consumption..... <40W
Working power.....AC110V-220V, 50Hz/60Hz

Mechanical

Installation: 19 "standard cabinet installation
Dimensions (W x D x H).....483*260*44.5(mm)
Working temperature.....-20°C~60°C
Relative humidity.....5%~95%
Storage and transportation temperature.....-40°C~80°C
Weight.....3KG

SPK Series

Full frequency linear POE column speaker



The SPK series full-frequency linear POE sound column adopts a 3-inch full-frequency unit, a wooden speaker, and a built-in POE amplifier, which has a high degree of sound reduction and DSP processing. The speaker only needs to connect a network cable to realize audio, power supply, DSP configuration and real-time signal control.

Features

- Built-in DSP processing, support gain, mute, equalization, pressure limit, noise gate software adjustment
- AUDIOLINK digital transmission protocol, ultra-low latency, wireless loss and interference
- A network cable transmits audio signals, control signals, and POE power
- Overcurrent protection, high temperature protection, overload protection

Specification

Mode	VIS-SPK12-AL	VIS-SPK8-AL	VIS-SPK6-AL	VIS-SPK4-AL	VIS-SPK2-AL
System Components	12 × 3 "full frequency unit	8 × 3 "full frequency unit	6 × 3 "full frequency unit	4 × 3 "full frequency unit	2 × 3 "full frequency unit
Frequency response (± 3dB)	120Hz-18kHz	120Hz-18kHz	130Hz-20kHz	135Hz-20kHz	140Hz-20kHz
Sensitivity	97dB	96dB / w / m	95dB / w / m	93dB / w / m	91dB / w / m
Maximum sound pressure level	121dB	120dB	119dB	117dB	113dB
Power	120W	120W	120W	120W	80W
Coverage angle	H100 ° × V15 °	H100 ° × V18 °	H100 ° × V20 °	H100 ° × V30 °	H100 ° × V40 °
Interface	1 way RJ45	1 way RJ45	1 way RJ45	1 way RJ45	1 way RJ45
Material	Wooden	Wooden	Wooden	Wooden	Wooden

Cooling method	Natural convection cooling	Natural convection cooling	Natural convection cooling	Natural convection cooling	Natural convection cooling
Size	124×155×101mm	120×150×720mm	120×150×540mm	120×150×370mm	120×150×210mm
Net weight	12kg	8.5kg	6.5kg	4kg	2.5kg

VIS-SPK101-AL/VIS-SPK801-AL/VIS-SPK602-AL

POE active speaker



The cabinet of speaker is made of multi-layer high-density birch plywood and built-in POE amplifier, which has a high degree of sound reduction and DSP processing. The concave and convex groove process is used to make the cabinet more solid. At the same time, the use of high-strength reinforcement nails causes the resonance of the cabinet. The energy distortion is minimized. The cabinet is designed to be moisture- proof and dust-proof to ensure stable operation in dusty and humid environments. The speaker only needs to connect a network cable to realize audio, power supply, DSP configuration and real-time signal control.

It's suitable for high- end performances, conferences, evenings and concert system.

Features

- Built-in DSP processing, support gain, mute, equalization, pressure limit, noise gate software adjustment
- AUDIOLINK digital transmission protocol, ultra-low latency, wireless loss and interference
- A network cable transmits audio signals, control signals, and POE power
- Overcurrent protection, high temperature protection, overload protection

Specification

Model	VIS-SPK101-AL	VIS-SPK801-AL	VIS-SPK602-AL
System Components	1 × 10" + 1 × 1.33"/50mm	System Components	1 × 10" + 1 × 1.33"/50mm
Frequency response(± 3dB)	60Hz-20kHz	65Hz-20kHz	70Hz-20kHz
Nominal impedance	8 Ohm	8 Ohm	4 Ohm
Frequency response(± 3dB)	60Hz-20kHz	65Hz-20kHz	70Hz-20kHz
Sensitivity	97dB/w/m	93dB / w / m	95dB / w / m
Maximum sound pressure level	128dB	120dB	122dB
Power	180W (AES), 720W(PEAK)	150W (AES), 600W (PEAK)	190W (AES), 760W (PEAK)
Coverage angle	H90 ° × V60 °	H90 ° × V60 °	H90 ° × V90 °

Interface	1 way RJ45	1 way RJ45	1 way RJ45
Material	Wooden	Wooden	Wooden
Cooling method	Natural convection cooling	Natural convection cooling	Natural convection cooling
Size	265×320×500mm	261×282×448mm	215×230×542mm
Net weight	13.2kg	9.7kg	11kg

VIS-X8D-AL

8 inch POE ceiling speaker



This model of POE speaker is installed on the ceiling, built-in POE amplifier, with gain, equalization, pressure limit, noise gate, mute control adjustment. The speaker only needs to connect a network cable to realize audio, power supply, DSP configuration and real-time signal control, compatible with 802.3af, compatible with 802.3at, natural convection heat dissipation. Ceiling speakers are widely used at Office buildings, hotels, and shopping malls are public places that use ceiling speakers.

Specification

System type..... 8" AUDIOLINK active coaxial ceiling speaker
Frequency response ($\pm 3\text{dB}$).....60Hz-20kHz
Unit.....1 \times 8" coaxial
Nominal impedance.....8 Ω
Power.....120W
Sensitivity.....89dB/w/m
Maximum sound pressure level.....113dB
Amplifier interface..... 1x RJ45
AUDIOLINK interface.....1 channel, with gain, equalization, pressure limit, noise gate, mute control adjustment.
Power supply.....PoE+, compatible with 802.3af, compatible with 802.3at, natural convection heat dissipation. Product size..... $\Phi 305 \times 215\text{mm}$
Hole size..... $\Phi 270\text{mm}$
Net weight.....4.5kg
Material.....galvanized iron drum

VIS-AMD2200/VIS-AMD2300/VIS-AMD2400/VIS-AMD4300

Power Amplifier



It is a series of cost-effective, high-reliability power amplifiers. It uses high-quality components. Through the use of innovative circuit design, with powerful power output, it can achieve amazing power output by switching the bridge mode, and flexibly combine to meet the requirements of more different occasions. The special low-temperature pure copper transformer, coupled with a large air volume heat dissipation system, guarantees the stable reproduction of perfect sound at any time.

Specification

Model	VIS-AMD2200	VIS-AMD2300	VIS-AMD2400	VIS-AMD4300
Rated output power	8Ω stereo 300W × 2	8Ω stereo 300W × 2	8Ω stereo 400W × 2	8Ω stereo 300W × 4
Rated output power.	4Ω stereo 300W × 2	4Ω stereo 500W × 2	4Ω stereo 650W × 2	4Ω stereo 500W × 4
Rated bridge output power	8Ω bridged 600W	8Ω bridged 900W	8Ω bridged 1200W	8Ω bridged 900W × 2
Power requirements	AC220V	AC220V	AC220V	AC220V
Structure	1U metal chassis	1U metal chassis	1U metal chassis	1U metal chassis
Number of channels	2CH	2CH	2CH	4CH
Harmonic distortion (1kHz, 4ohms)	<0.1%	<0.1%	<0.1%	<0.1%
Frequency response	15Hz-20kHz: ± 0.1dB (1W / 8Ω)	15Hz-20kHz: ± 0.1dB (1W / 8Ω)	15Hz-20kHz: ± 0.1dB (1W / 8Ω)	15Hz-20kHz: ± 0.1dB (1W / 8Ω)
Input impedance	Balanced 20K ohm	Balanced 20K ohm	Balanced 20K ohm	Balanced 20K ohm
unbalanced 10K Ohm sensitivity	0.775V	0.775V	0.775V	0.775V
Signal to noise ratio	≥100dB	≥100dB	≥100dB	≥100dB
Damping coefficient	(350: 1, 1Khz 8ohms)	(350: 1, 1Khz 8ohms)	(350: 1, 1Khz 8ohms)	(350: 1, 1Khz 8ohms)

Conversion rate	28V / US	28V / US	28V / US	28V / US
Output stage	Class-D	Class-D	Class-D	Class-D
LED indicator	power / signal / distortion / clipping	power / signal / distortion / clipping	power / signal / distortion / clipping	power / signal / distortion / clipping
Input connector	Balanced male and female XLR	Balanced male and female XLR	Balanced male and female XLR	Balanced male and female XLR
Cooling system	dual variable speed fans,exhaust air from front to back	dual variable speed fans,exhaust air from front to back	dual variable speed fans,exhaust air from front to back	dual variable speed fans,exhaust air from front to back
Protection function	overheat, short circuit, DC output	overheat, short circuit, DC output	overheat, short circuit, DC output	overheat, short circuit, DC output
Dimensions	482 × 295 × 44mm	482 × 295 × 44mm	482 × 295 × 44mm	482 × 295 × 44mm

VIS-HL002/ HL003/ HL005/ HL010/ HL020/ HL050/HL100

Professional CAT5E conference extension cables



Features

- TIA/EIA 568B CAT5E
- ISO/IEC 11801 ClassD
- CELENEC EN50173, EN50167, EN50169
- UL C(UL)&ETL Verified
- Pre-test by VISSONIC

Functions

- Extension cable for main unit to CU/DU unit
- Carry 48DC power and signals
- Male to Male cable
- Size from 2m to 100m

Interfaces

2x male RJ45

Specification

Standard.....TIA/EIA 568B CAT5E
Connector.....Shielded RJ45 Shielding: F/UTP
Resistance.....100ohm±15%,1MHz to 100MHz
Delay skew.....25ns/100m max
Gauge.....24AWG solid bare copper
Flame retardant rating.....CM, IEC332/1
Storage Temperature.....-20°C~80°C
Operation temperature..... -20°C~60°C

Item Model for Order

- VIS-HL002.....2m black shielded Cat5e U/FTP cable (shielded RJ45)
- VIS-HL003.....3m black shielded Cat5e U/FTP cable (shielded RJ45)
- VIS-HL005.....5m black shielded Cat5e U/FTP cable (shielded RJ45)
- VIS-HL010.....10m black shielded Cat5e U/FTP cable (shielded RJ45)
- VIS-HL020.....20m black shielded Cat5e U/FTP cable (shielded RJ45)
- VIS-HL050.....50m black shielded Cat5e U/FTP cable (shielded RJ45)
- VIS-HL100.....100m black shielded Cat5e U/FTP cable (shielded RJ45)

About VISSONIC Electronics Limited

Our mission is to develop and manufacture the most comprehensive and innovative audio visual products for our clients. We provide the best performance/price ratio products because it could give you satisfaction just from the time you use them, we believe the good design with cutting edge technology on products will provide value to all our partners and end users. Listen to your demands, we fulfill it.



4/F, Building G7, No. 31 Kefeng Road, Huangpu district, Guangzhou, China

• Tel: +86-020-82515140 • E-mail: info@vissonic.com

©2024 VISSONIC Electronics Ltd. all rights reserved.