

VISSONIC







X9 Series Modular Video Wall Processor User Manual Version 4.0



The indications of symbols

■ Safety instructions

Some symbols pointing out the potential risk of injury and property loss are used in the instructions and devices, to help you use the devices safely and properly. Symbols and their indications are as follows. Please make sure that you have known these instructions before reading the manual.

	Remind users to operate and maintenance according to the instructions attached to the devices. If ignoring this information, it may cause death or injury due to wrong operations.
	Remind users that uninsulated dangerous voltage in devices may lead to electric shock.
	CE certification means that the product has reached the safety requirements specified by EU regulations, users can be assured.
	SGS certification means that the product has reached the quality standards of the world's largest Societe Generale de Surveillance.
	This product has passed ISO9001 international quality certification (certification bodies: Rheinland TUV).
	WARNING: To avoid electric shock, do not open the cover, and do not place unnecessary portion in the chassis. Please contact qualified service personnel.

■ General information indications

	Information that may lead to an unsuccessful operation or setting and other relevant information needed to be noticed is listed.
---	--

Important notes



Warning

To ensure reliable use of devices and safety of personnel, please observe the following items in the installation, use and maintenance.

Notes in installation

- ◆ Do not use this product in the following places: Where exists dust, smoke, conductive dust, corrosive gases or flammable gases; where exposes to high temperature, condensation or wind and rain; where exists vibration and shock. Electric shock, fire, incorrect operation will also lead to product damage and deterioration;
- ◆ During screw hole processing and wiring, metal chips and wire heads shall not be dropped into ventilation holes of controllers, which may cause a fire, malfunction or incorrect operation;
- ◆ When the installation work is done, make sure that no foreign body is left on the surface of ventilation, including contact paper and other packaging materials, otherwise it may lead to poor run-time heat, causing a fire, malfunction or incorrect operation;
- ◆ Avoid wiring or inserting/pulling plugs in charged state, otherwise it may easily lead to electric shock or cause damage to the circuit;
- ◆ Installation and wiring must be solid and reliable, poor contact may result in incorrect operation;
- ◆ For application in occasions with severe interference, shielded cables should be used to input and output high-frequency signal so that anti-interference performance of the system could be improved.

Notes in wiring

- ◆ All of the external power supply must be cut off before carrying out installation, wiring and other operations, or it may cause electric shock or equipment damage;
- ◆ This product is grounded through the grounding conductor of the power cord. In order to avoid electric shock, the grounding conductor must be connected to earth. Before connecting the input or output terminals of the product, make sure that the product is properly grounded;
- ◆ Once wiring is completed, foreign matters should be immediately removed. Please cover the terminal covers of product before power connection to avoid electric shock.

Notes in operation and maintenance

- ◆ Do not touch the terminal when power is on, or it may cause electric shock or incorrect operation;
- ◆ Perform cleaning and terminal tightening when power is off, for these operations may cause electric shock when power is on;
- ◆ Perform connection, removal or other operations of the communication signal cables and the cables of expansion board or control unit after power is off, or it may cause equipment damage or incorrect operation;
- ◆ Do not disassemble the equipment, so as not to damage the internal electrical components;
- ◆ Always read the manual, after security fully recognized, changing the program, commissioning, starting and stopping operations after security is fully recognized;
- ◆ Button batteries must be replaced when the power is off. When you indeed need to replace the button batteries with the power on, the operation should be performed by a qualified electrical technician wearing insulated gloves.

Notes in product obsolescence

- ◆ Explosive electrolytic capacitors: It may cause explosion when electrolytic capacitor on the circuit board burns;
- ◆ Please collect and process separately, it cannot be put in the life garbage;
- ◆ Please process it as industrial waste, or process it in accordance with local environmental regulations.

Contents

Chapter 1 Overview.....	6
1.1 Product Equipment	6
1.2 function features	7
1.3 Cabinet installation	7
Chapter 2 Hardware Introductions.....	9
2.1 VW-VM0808 panel diagram	9
2.2 VW-VM1616 panel diagram	9
2.3 VW-VM3636 panel diagram	10
2.4 VW-VM7272 panel diagram	12
2.5 VW-VM144144 panel diagram	14
2.6 Link of matrix and peripherals	16
2.6.1 Input interface description	16
2.6.2 Output interface description	16
2.6.3 Control board communication port and link method.....	16
2.6.4 Matrix RS-232 control interface	16
2.6.5 Link of matrix and control computer	17
2.6.6 Matrix KEYBOARD interface	17
2.6.7 Link of matrix and extended keyboard	17
2.6.8 Ethernet/PR-LINK Interface.....	18
2.6.8.1 Hardware linking method	18
2.6.8.2 Connection Method Description of RJ45 Ethernet Port straight-through Line and Cross-line.....	19
2.6.9 HDMI port description	20
2.6.10 DVI port description	20
2.6.11 DB15 interface description	21
2.6.12 DB15 male socket transfer cable (S terminal, RCA head).....	22
2.6.12.1 DB15 male socket transfer cable definition.....	23
Chapter 3 Control Panel Operating Instructions.....	24
3.1 Panel description.....	24
3.2 Board types	25
3.3 Input board.....	26
3.3.1 VW-HM4I input board function	26
3.3.2 VW-HM2I input board function	27
3.3.3 VW-HD4I CAT5 input board function	27
3.3.4 VW-IP2I IP input board function.....	27
3.3.5 VW-SD4I input board function.....	27
3.3.6 VW-VA4I input board function	27
3.3.7 VW-DV4I input board function.....	28
3.3.8 VW-SF4I optical fiber input board function.....	28
3.4 Output board.....	28
3.4.1 VW-HM4O seamless output board function.....	28
3.4.2 VW-HM2O 4K seamless output board function.....	28

3.4.3 VW-HD4O CAT5 seamless output board function.....	28
3.4.4 VW-SD4O seamless output board	29
3.4.5 VW-DV4O seamless output board function	29
3.4.6 VW-VA4O seamless output board function.....	29
3.4.7 VW-SF4O optical fiber seamless output board function	29
3.4.8 VW-STM4 streaming media output board function	29
3.4.9 VP-HM4O stitching output board function	29
3.4.10 VP-HM2O stitching output board function	30
3.4.11 VP-HM2O-4K stitching output board function	30
3.4.12 VP-DV4O stitching output board function	30
3.4.13 VP-DV2O stitching output board function	30
3.4.14 VP-HD4O stitching output board function	30
3.4.15 VP-HD2O stitching output board function	30
3.5 Preview board.....	30
3.5.1 VW-PVW preview board function.....	30
3.6 Control board.....	31
3.6.1 VW-Con ETN5 advanced control board function.....	31
3.7 Specification and Parameter	32
3.7.1 VW-HM4I and VW-HM4O	32
3.7.2 VW-HM2I and VW-HM2O	32
3.7.3 VW-DV4I and VW-DV4O	33
3.7.4 VW-HD4I and VW-HD4O	34
3.7.5 VW-VA4I and VW-VA4O	35
3.7.6 VW-SD4I and VW-SD4O.....	35
3.7.7 VW-SF4I and VW-SF4O	36
3.7.8 VW-IP2I.....	36
3.7.9 VP-HM4O.....	37
3.7.10 VP-HM2O.....	38
3.7.11 VP-HM2O-4K	38
3.7.12 VP-DV4O	39
3.7.13 VP-DV2O	40
3.7.14 VP-HD4O	41
3.7.15 VP-HD2O	41
3.7.16 VW-PVW.....	42
3.7.17 VW-VM0808/1616/3636/7272/144144.....	43
3.8 Front Panel Operation.....	44
Chapter 4 Instructions.....	48
4.1 X9 processor instructions	48
4.2 Splicer instructions	55

Chapter 1 Overview

X9 series Modular video wall processor can realize graphics processing and seamless switching flexibly. The matrix adopts high-performance hardware design, perfectly supports a variety of high-definition digital / analog signal switching and processing, and supports two-way RS-232, two-way IR signal assigned switching function. It can also divide a completed image signal into several signals assigned to several different display unites, forming a large display screen to display dynamic images. It provides a one-stop solution for various industries to assign, switch and process a variety of video and control signals, which can be widely used in radio and television engineering, multimedia conference room, large-screen display engineering, television teaching, intelligent traffic management centers, command and control centers and other places.

X9 series Modular video wall processor contains 0808,1616,3636,7272 and other models, its signal input/output interface contains HDMI, DVI, VGA, HDBaseT, SDI, optical fiber and other video interfaces. Leading all-digital signal processing technology ensures undistorted processing, sending top quality screen to the display terminal. With customized configuration of various types of the same or different input/output boards, single interface type or multi interface type of matrix can be formed, such as optical fiber matrix, HDMI matrix, DVI matrix, CAT5 matrix, VGA matrix, YUV matrix, Video matrix and so on.

X9 series Modular video wall processor provides a variety of control modes, with remote control operation, RS-485 extended keyboard, but also provides two standard RS-232 communication interfaces and network ports, convenient for users to coordinate it with various remote control devices.

1.1 Product Equipment

VW-VM0808
VW-VM1616
VW-VM3636
VW-VM7272
VW-VM144144

Modular video wall processor can be composed of any of the following input and output boards.

Input boards:

- ◆ VW-HM4I input board (HDMI signal input)
- ◆ VW-HM2I input board (HDMI 2 signal input)
- ◆ VW-HD4I CAT5 input board (HDBaseT signal input)
- ◆ VW-IP2I IP streaming media decoding input board (H.264 IP streaming media encoding input)
- ◆ VW-SD4I input board (SDI signal input)
- ◆ VW-VA4I input board (YPbPr, VGA signal input)
- ◆ VW-DV4I input board (DVI signal input)
- ◆ VW-SF4I optical fiber input board (OPTICAL FIBER signal input)

Seamless output boards:

- ◆ VW-HM4O seamless output board (HDMI signal output)
- ◆ VW-HM2O4K seamless output board (two 4K×2K HDMI signal output)
- ◆ VW-HD4O CAT5 seamless output board (HDBaseT signal output)
- ◆ VW-SD4O seamless output board (SDI signal output)
- ◆ VW-DV4O seamless output board (DVI signal output)
- ◆ VW-VA4O seamless output board (YPbPr, VGA signal output)
- ◆ VW-SF4O optical fiber seamless output board (OPTICAL FIBER signal output)
- ◆ VW-STM4 streaming media output board (one

RJ45 port of streaming media output)

Video wall output boards:

- ◆ VP-HM4O stitching output board (HDMI signal output)
- ◆ VP-HM2O stitching output board (2 HDMI signal output)
- ◆ VP-HM2O-4K HDMI stitching output board (2 ports, single port HDMI 4K stitching 2 window output)
- ◆ VP-DV4O stitching output board (DVI signal output)
- ◆ VP-DV2O stitching output board (2 DVI signal output)
- ◆ VP-HD4O CAT5 stitching output board (HDBaseT signal output)
- ◆ VP-HD2O CAT5 stitching output board (HDBaseT signal output)

Preview board:

- ◆ VW-PVW preview board (video signal encode output)

Control board:

- ◆ VW-Con ETN5 advanced control board

1.2 function features

- ◆ All digital switching, each seamless output board can realize real-time seamless switching;
- ◆ Each stitching output board can realize video stitching; picture windows in full screen can zoom, overlay and roam arbitrarily;
- ◆ Preview board can realize previewing videos by group and switching function;
- ◆ Support DVI 1.0 protocol, in line with HDCP 1.4, compatible with HDMI 1.4a;
- ◆ Support hot plug, support audio and video signal switching together;
- ◆ Digital audio and analog audio in HDMI input board can be input selectively, digital audio and analog audio in HDMI output board can be output simultaneously;

- ◆ Support PC software control switching and EDID management;
- ◆ HDBaseT input and output signals support embedded (or local) bi-directional RS-232 and bi-directional IR signals, and can choose to switch with video signals or separate switching modes, and support POC external power supply;
- ◆ Flexible control with infrared remote control, RS485, RS232 communication interface and network ports, and can be controlled by distant HDBaseT / optical fiber serial ports, convenient for users to coordinate it with various remote control devices;
- ◆ Firmware upgrade online;
- ◆ Character overlay;
- ◆ Maximum resolution up to 4K x 2K;
- ◆ Intelligent control matrix fan operation;
- ◆ SDI input board has looping out function;
- ◆ VW-VM3636 and its upgrades have redundant power supply design;
- ◆ Plug-in board structure design, flexibly allocate input/output signal type and signal channel number.

1.3 Cabinet installation

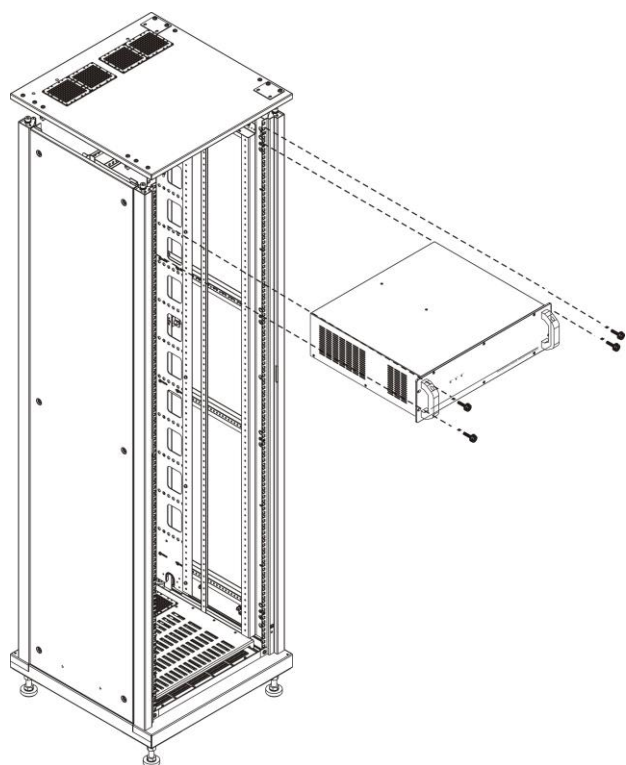

1.4 System connection diagram

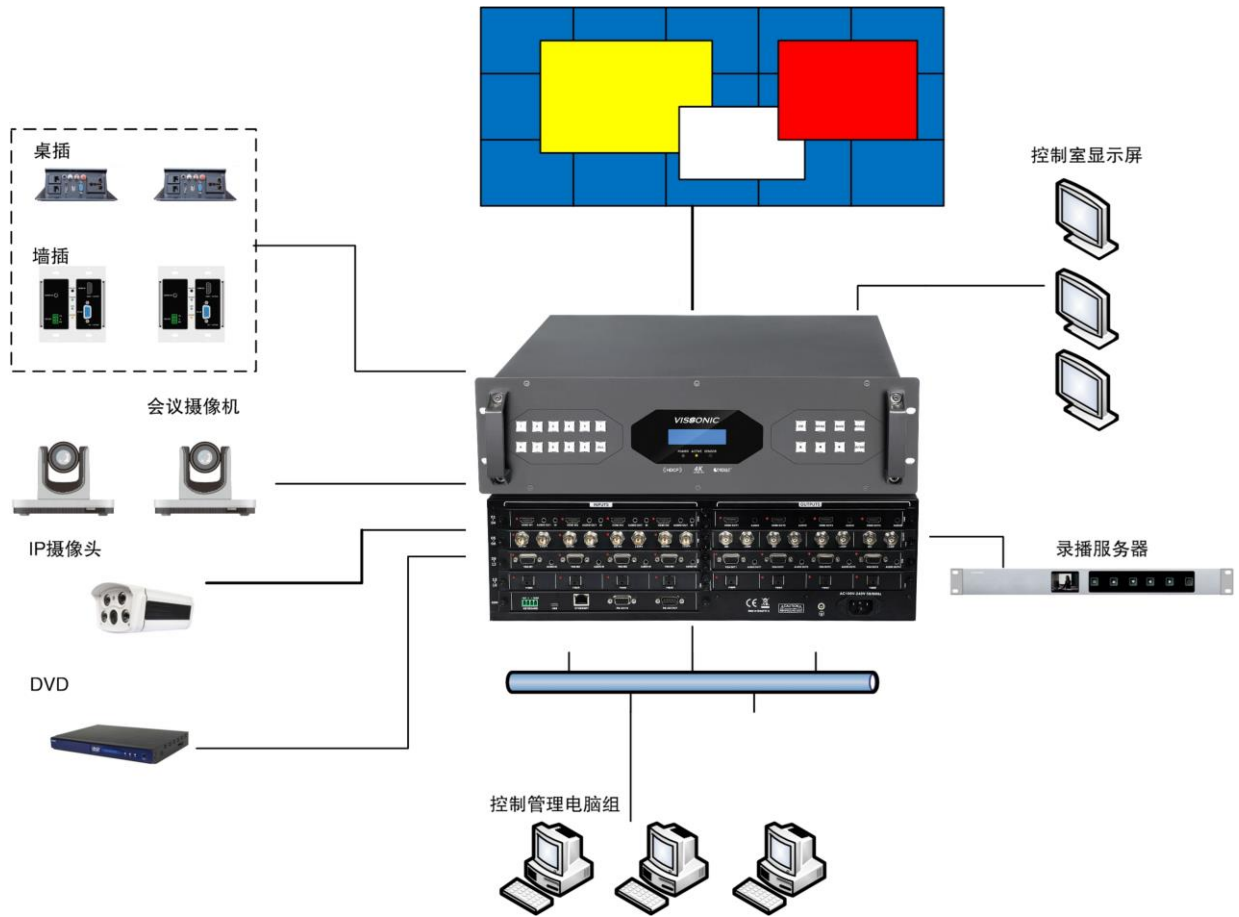

Chapter 2 Hardware Introductions

2.1 VW-VM0808 panel diagram

VW-VM0808 front panel:

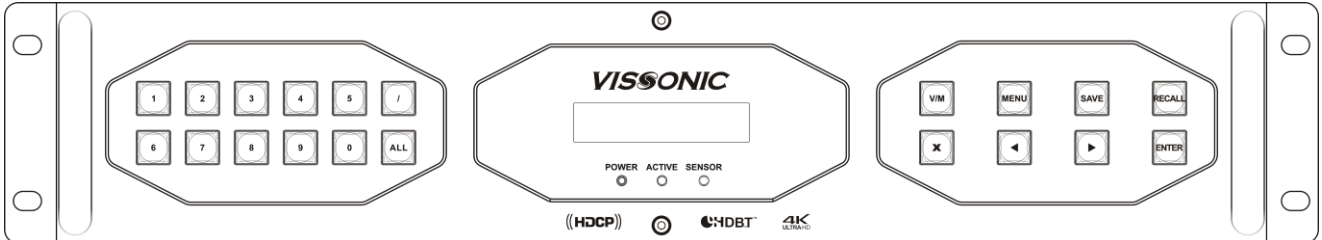

VW-VM0808 back panel:

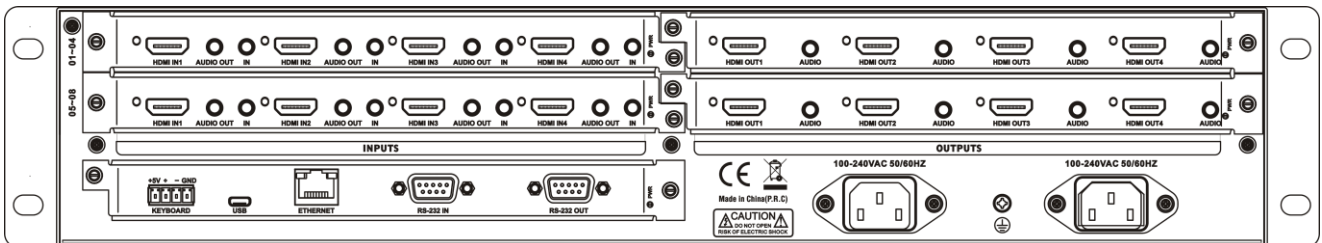

2.2 VW-VM1616 panel diagram

VW-VM1616 front panel:

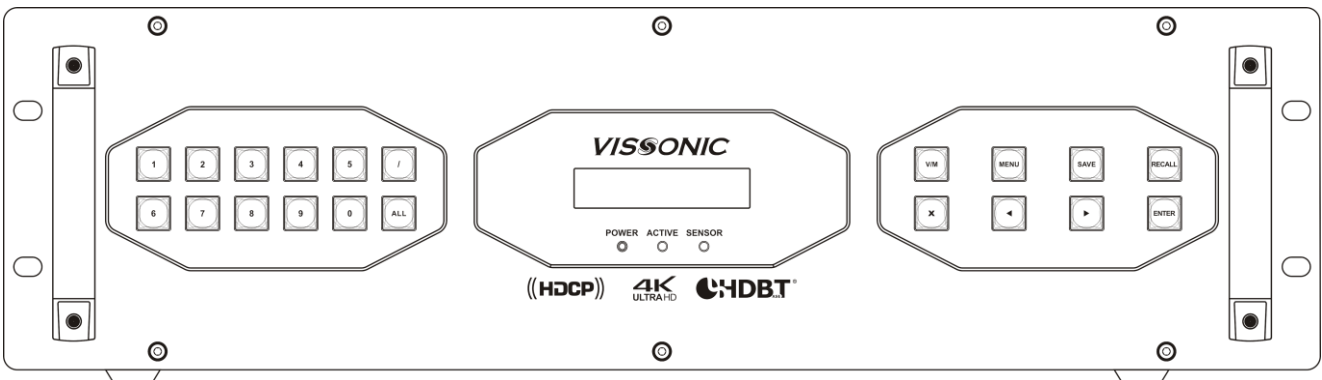

VW-VM1616 back panel:

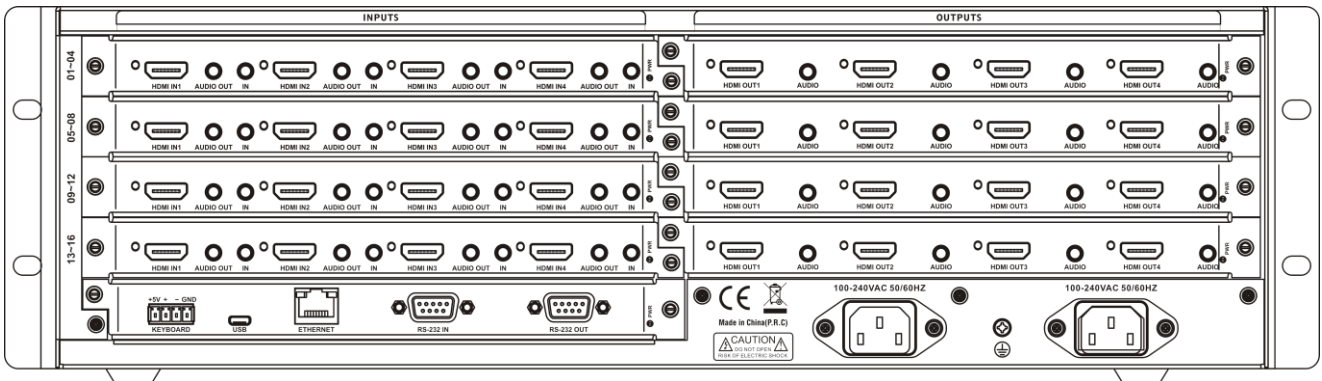

2.3 VW-VM3636 panel diagram

VW-VM3636 front panel:

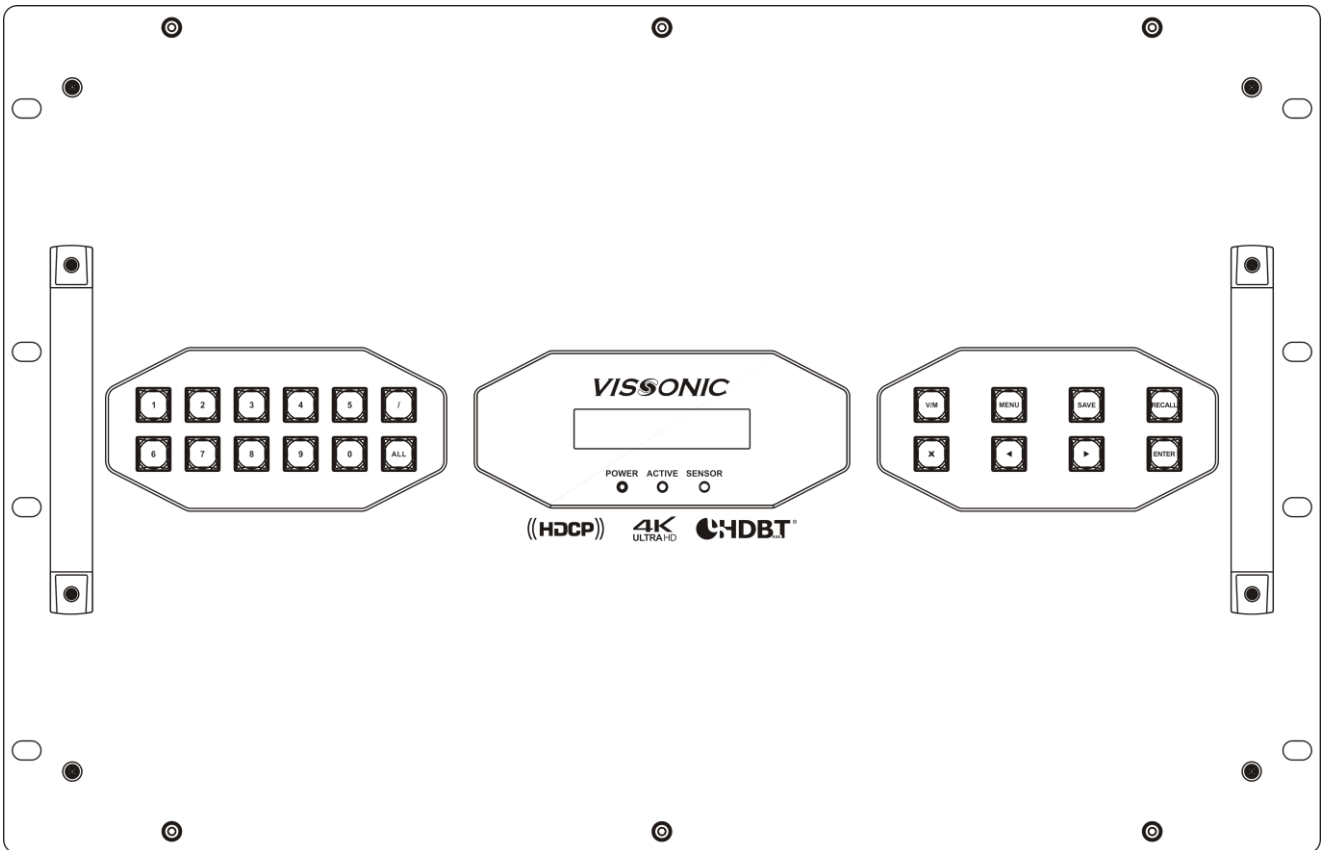

VW-VM3636 back panel:

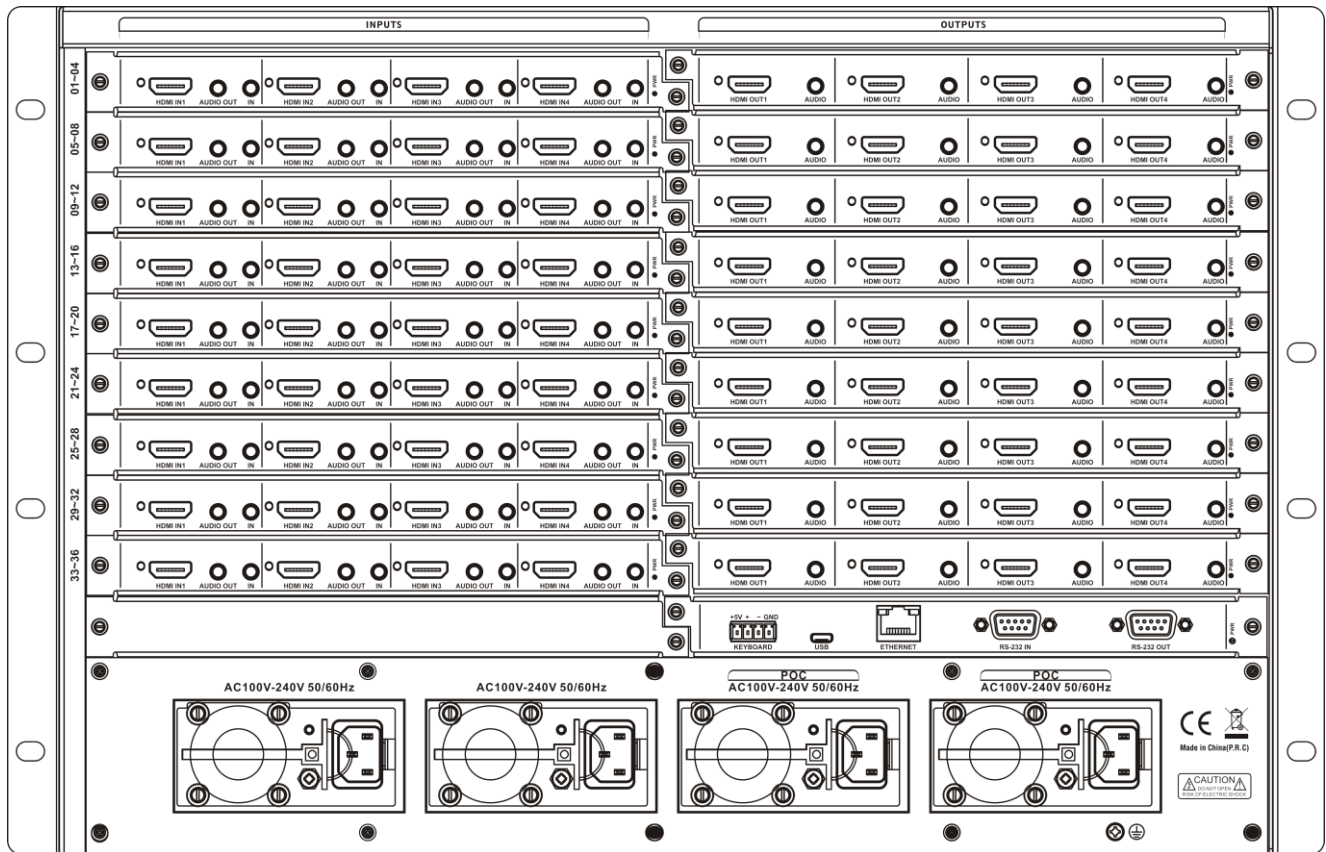

2.4 VW-VM7272 panel diagram

VW-VM7272 front panel:

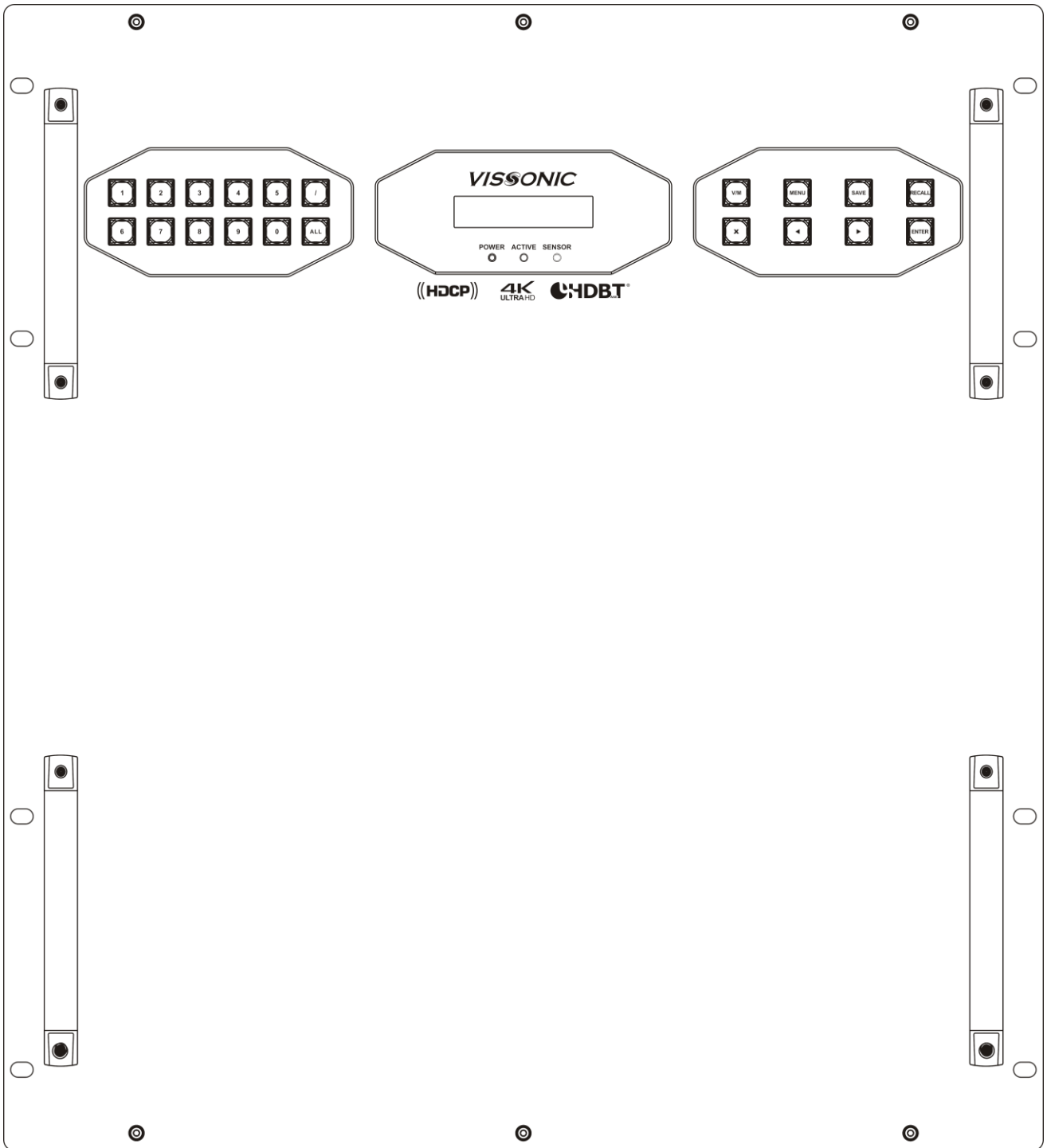

VW-VM7272 back panel:

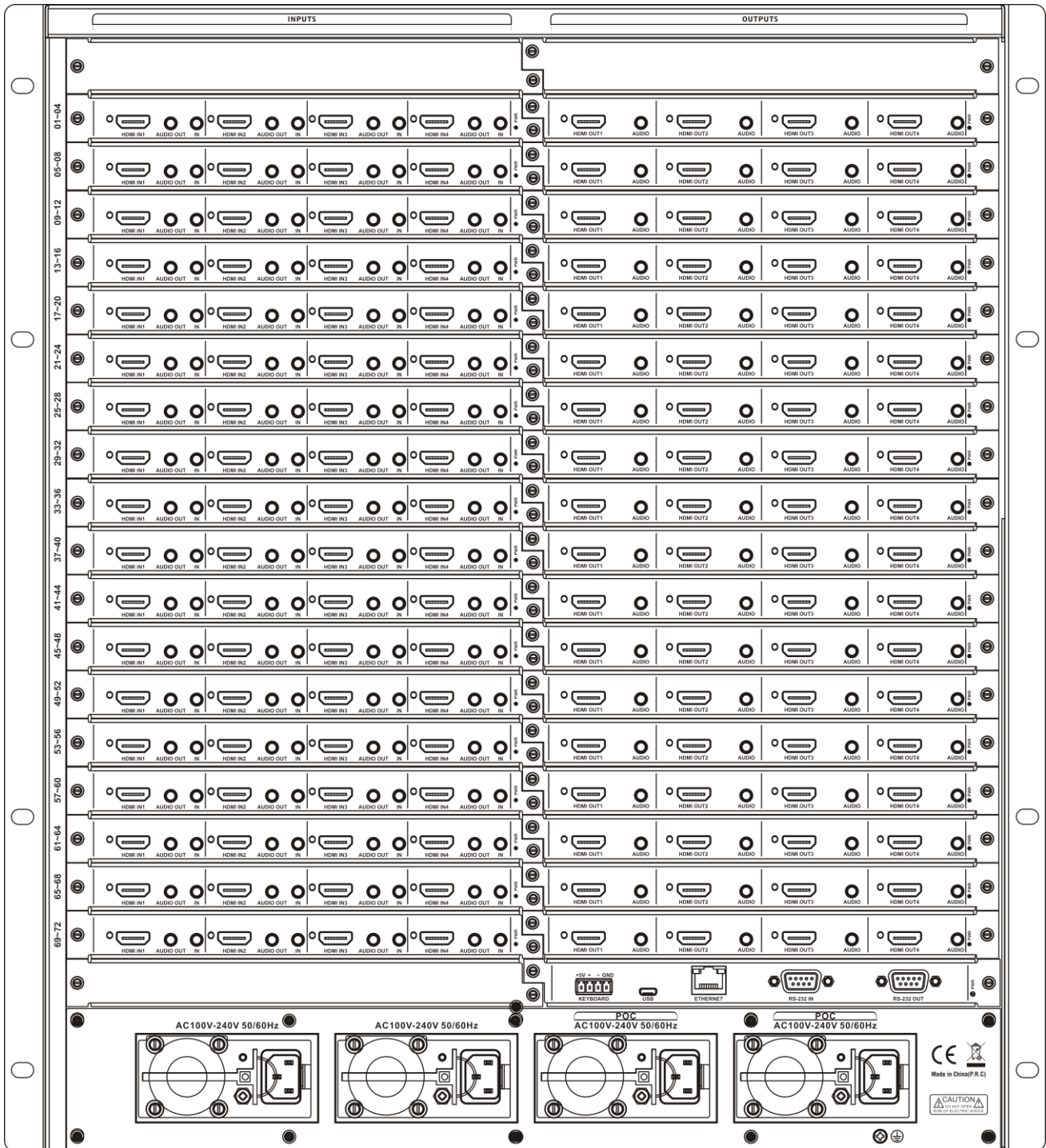

2.5 VW-VM144144 panel diagram

VW-VM144144 front panel:

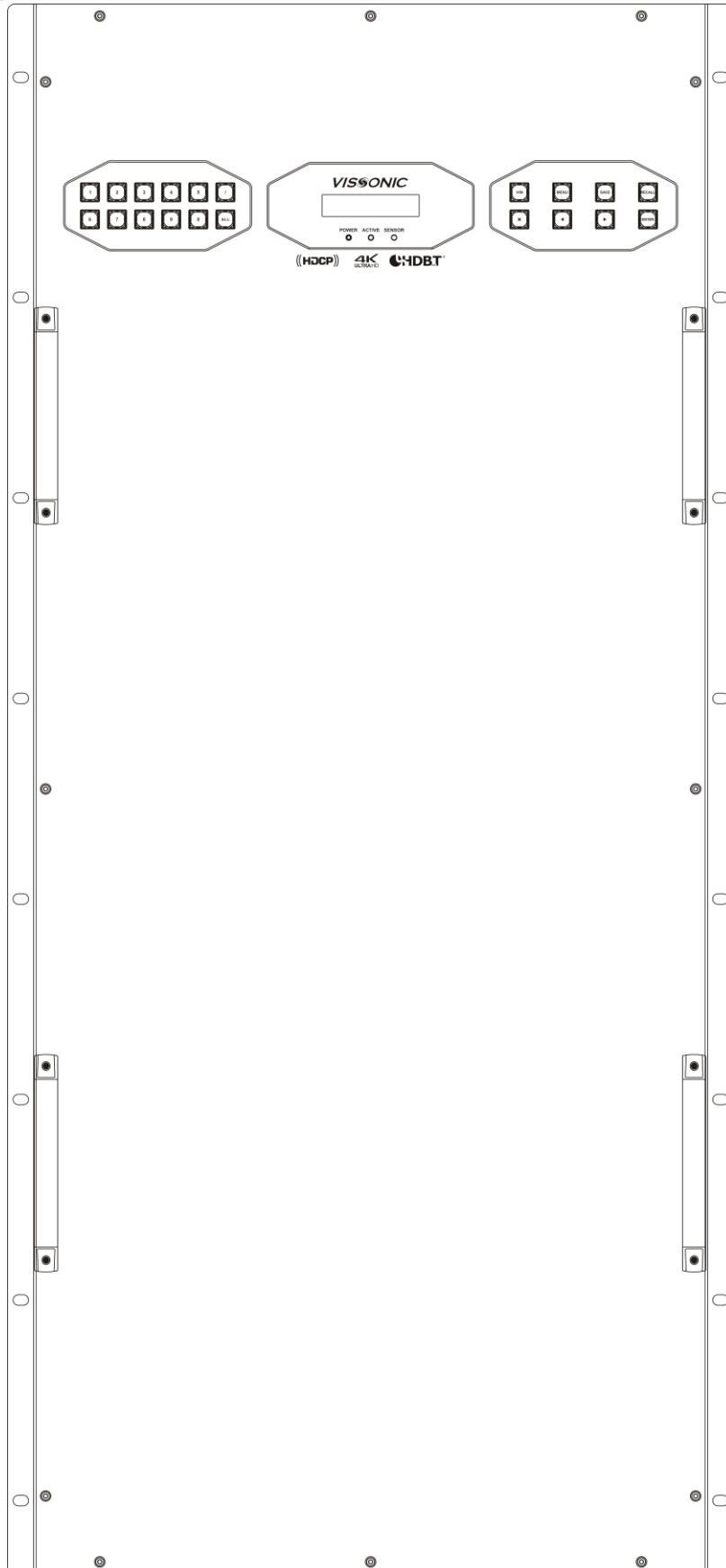

VW-VM144144 back panel:

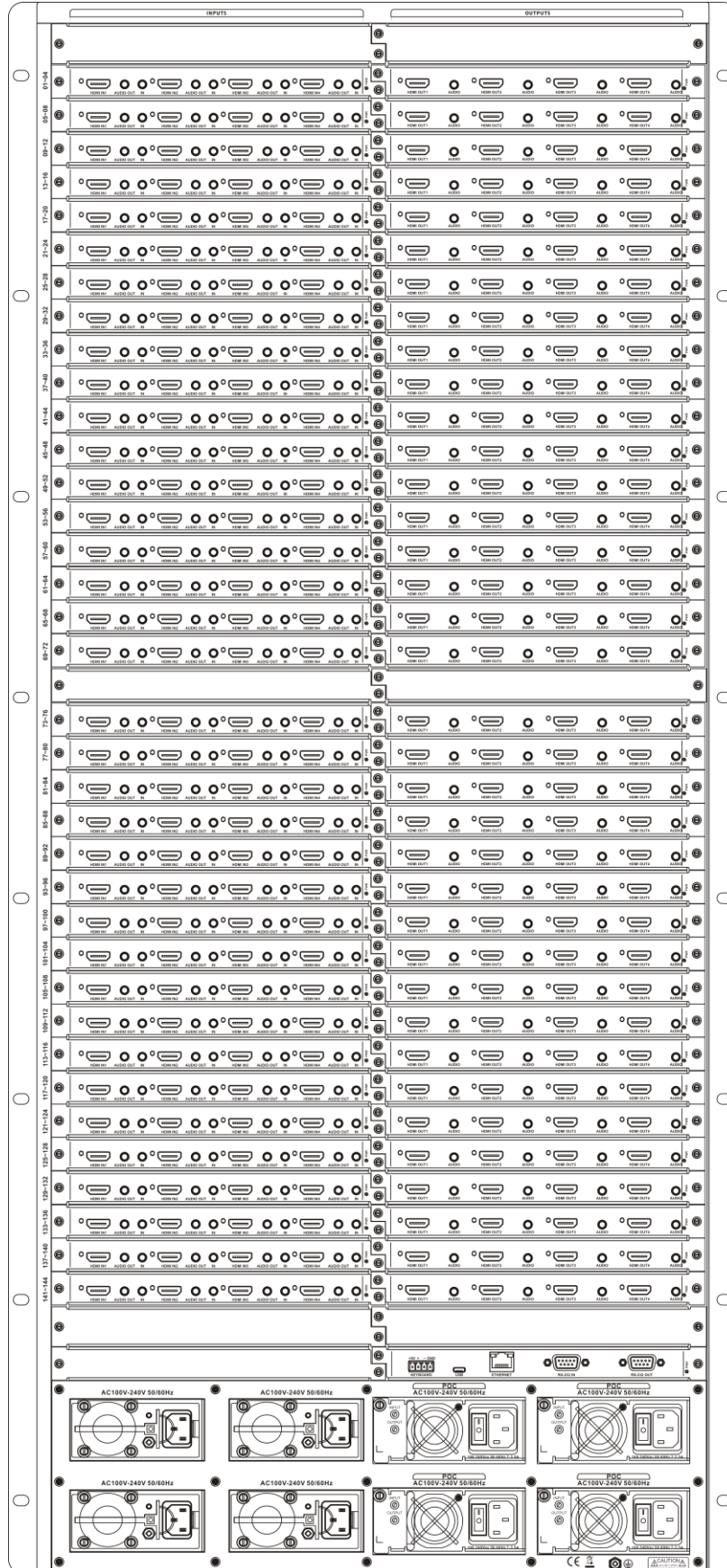

2.6 Link of matrix and peripherals

2.6.1 Input interface description

The input interface is composed of VW-HM4I, VW-HM2I, VW-HD4I, VW-IP2I, VW-SD4I, VW-VA4I, VW-DV4I and VW-SF4I input board, enable to combine various input signal formats arbitrarily.

2.6.2 Output interface description

The output interface is composed of VW-HM4O, VW-HM2O, VW-HD4O, VW-SD4O, VW-DV4O, VW-VA4O, VW-SF4O, VW-STM4 seamless output board and VP-HM4O, VP-HM2O, VP-HM2O-4K, VP-DV4O, VP-DV2O, VP-HD4O, VP-HD2O stitching output board, enable to combine various input signal formats arbitrarily.

2.6.3 Control board communication port and link method

X9 modular matrix provides standard RS-232 serial communication ports, in addition to realize switching operations with infrared remote control, it can also control by using a variety of control systems (such as PC, VISSONIC control systems, control systems of other manufacturers, etc.).

2.6.4 Matrix RS-232 control interface

Modular matrix provides two RS-232 serial interfaces (a DB9 female connector, a DB9 male connector), you can use this interface to control the matrix. Pin description of RS-232 port DB9 female connector is as follows:

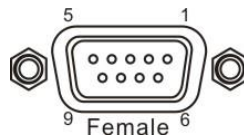

pin	signal	description
1	-	-
2	TXD	RS-232 protocol, sending data
3	RXD	RS-232 protocol, receiving data
4	-	-
5	GND	Signal ground
6	-	-
7	-	-
8	-	-
9	-	-

Pin description of RS-232 port DB9 male connector is as follows:

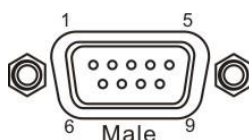

pin	signal	description
1	-	-
2	RXD	RS-232 protocol, sending data

3	TXD	RS-232 protocol, receiving data
4	-	-
5	GND	Signal ground
6	-	-
7	-	-
8	-	-
9	-	-

2.6.5 Link of matrix and control computer

With RS232 cable to link the computer's serial communication port (COM1 or COM2) and the matrix cabinet's RS-232 communication port, and use control command to control. For more details, refer to *Chapter 5, Instructions*.

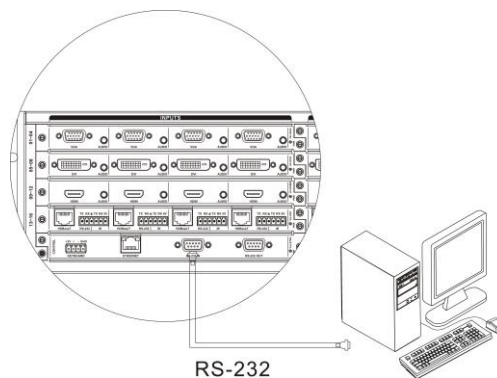

2.6.6 Matrix KEYBOARD interface

The matrix provides one KEYBOARD interface, it is used to link with extended keyboard VIS-MKB100 so that you can switch the channels of the matrix. KEYBOARD is a four-foot 3.8mm phoenix interface, its pin description is as follows:

pin	signal	description
1	+5V	Output DC 5 V/1 A, enable to provide power for MKB100
2	+	RS-485 protocol, DATA+
3	-	RS-485 protocol, DATA-
4	GND	Signal ground

2.6.7 Link of matrix and extended keyboard

Based on screen printing, correspondingly connect matrix cabinet KEYBOARD interface with extended keyboard VIS-MKB100's MATRIX interface, then you can control the matrix. For more details, refer to *User's Manual of VIS-MKB100 Matrix Keyboard*.

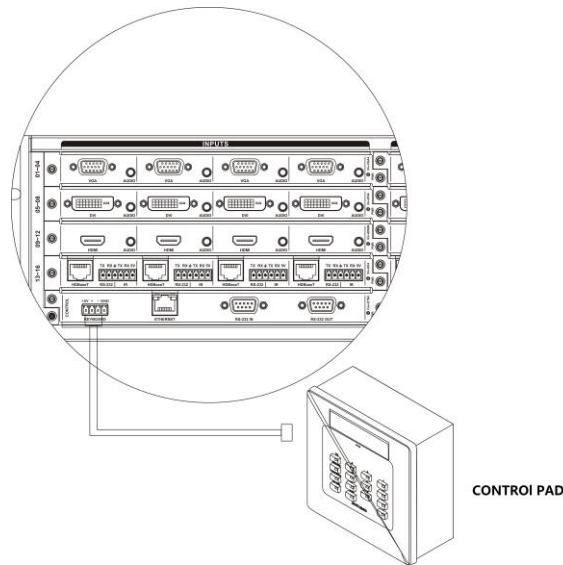

2.6.8 Ethernet/PR-LINK Interface

2.6.8.1 Hardware linking method

There are two ways to link matrix with Ethernet adapter hardware:

1) Cross-connect method

Matrix and control computer is directly connected via CAT5e crossover cable to connect the control board on Ethernet port (Default IP:192.168.1.190, Port:6666) as Picture no.1.

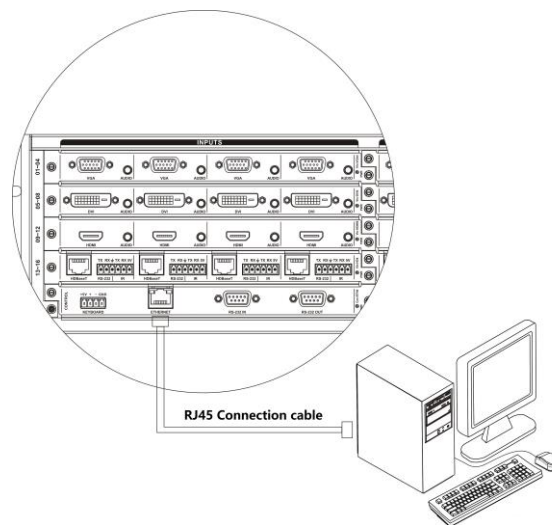

If the matrix is installed with preview board VW-PVW. There are no need to link the Ethernet port on the control board. Just need to connect the PC to the preview board 'PR-LINK' port (default IP:192.168.1.163, port: 5000) as Picture no.2.

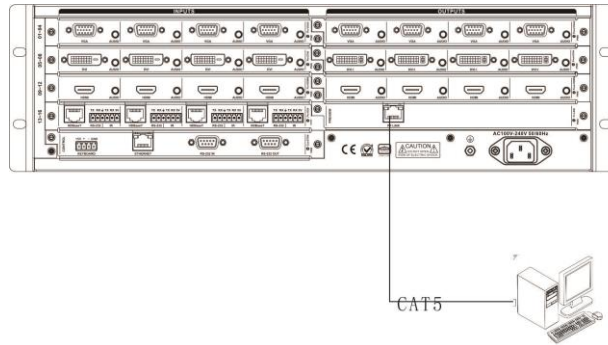

2) Through-connect method

Matrix and Switch is connected via CAT5e straight-through cable.

2.6.8.2 Connection Method Description of RJ45 Ethernet Port straight-through Line and Cross-line

The system adopts CAT5e (super 5-type line) as wires, using RJ45 connector (commonly known as crystal head) of CAT5e to connect network devices. Standard twisted-pair connection method is specifically regulated, aiming to ensure the symmetry of cable connector layout so that the interference between the cables within the connector can be offset. Super 5-type line in general has four pairs of wires twisted together, with different colors.

There are two ways to connect twisted pair: EIA/TIA 568B standard and EIA/TIA 568A standard.

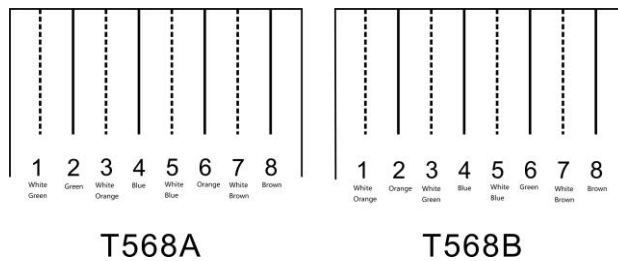

T568A line order							
1	2	3	4	5	6	7	8
White Green	Green	White Orange	Blue	White Blue	Orange	White Brown	Brown
T568B line order							
1	2	3	4	5	6	7	8
White orange	Orange	white Green	Blue	White Blue	Green	White Brown	Brown

Straight-through line: both ends are connected in T568B line order.

Crossover line: one end is connected in T568A line order, the other end is connected in T568B line order.

2.6.9 HDMI port description

HDMI-A Type Line description:

Users can connect a variety of computer signals, audio and video signal equipments, such as DVD players, desktop computers, graphics workstations, and number displays in different occasions, output terminals can be connected to the projector, VCRs, computer monitors, amplifiers and so on.

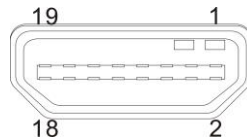

PIN	Function
1	TMDS Data2+
2	TMDS Data2 Shield
3	TMDS Data2-
4	TMDS Data1+
5	TMDS Data1 Shield
6	TMDS Data1-
7	TMDS Data0+
8	TMDS Data0 Shield
9	TMDS Data0-
10	TMDS Clock+
11	TMDS Clock Shield
12	TMDS Clock-
13	CEC
14	Reserved (in cable but N.C. on device)
15	SCL
16	SDA
17	DDC/CEC Ground
18	+5V Power
19	Hot Plug Detect

2.6.10 DVI port description

DVI-D Dual Link interface description

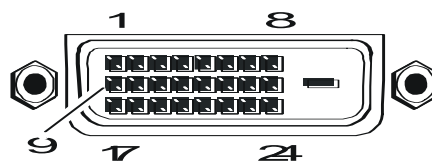

PIN	Function
1	T.M.D.S. Data2 -
2	T.M.D.S. Data2 +
3	T.M.D.S. Data2/4 Shield
4	T.M.D.S. Data4 -
5	T.M.D.S. Data4 +
6	DDC Clock
7	DDC Data
8	No Connect
9	T.M.D.S. Data1 -
10	T.M.D.S. Data1 +
11	T.M.D.S. Data1/3 Shield
12	T.M.D.S. Data3 -
13	T.M.D.S. Data3 +
14	+5 V Power
15	Ground (for +5 V)
16	Hot Plug Detect
17	T.M.D.S. Data0 -
18	T.M.D.S. Data0 +
19	T.M.D.S. Data0/5 Shield
20	T.M.D.S. Data5 -
21	T.M.D.S. Data5 +
22	T.M.D.S. Clock Shield
23	T.M.D.S. Clock +
24	T.M.D.S. Clock -

2.6.11 DB15 interface description

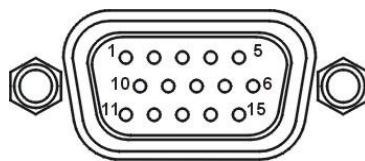

Pin description of component video DB15 port is as follows:

PIN	VGA	Component	S-Video	Composite
1	RED	Pr	N/C	N/C
2	GREEN	Y	N/C	N/C
3	BLUE	Pb	N/C	N/C
4	ID2	N/C	N/C	CVBS
5	GND	GND	N/C	GND
6	GND	GND	GND	N/C

7	GND	GND	GND	N/C
8	GND	N/C	N/C	N/C
9	N/C	N/C	Y	N/C
10	GND	N/C	N/C	N/C
11	N/C	N/C	C	N/C
12	SDA	N/C	N/C	N/C
13	HSYNC	N/C	N/C	N/C
14	VSYNC	N/C	N/C	N/C
15	SCL	N/C	N/C	N/C

Pin description of VGA video output board is as follows:

pin	signal	description
1	RED	red primary
2	GREEN	green primary
3	BLUE	blue primary
4	ID2	address code 2
5	GND	ground
6	RGND	red ground
7	GGND	green ground
8	BGND	blue ground
9	KEY	reserved
10	SGND	digital ground
11	ID0	address code 0
12	SDA	data pin
13	HSYNC	horizontal synchronization
14	VSYNC	vertical synchronization
15	SCL	clock signal

2.6.12 DB15 male socket transfer cable (S terminal, RCA head)



2.6.12.1 DB15 male socket transfer cable definition

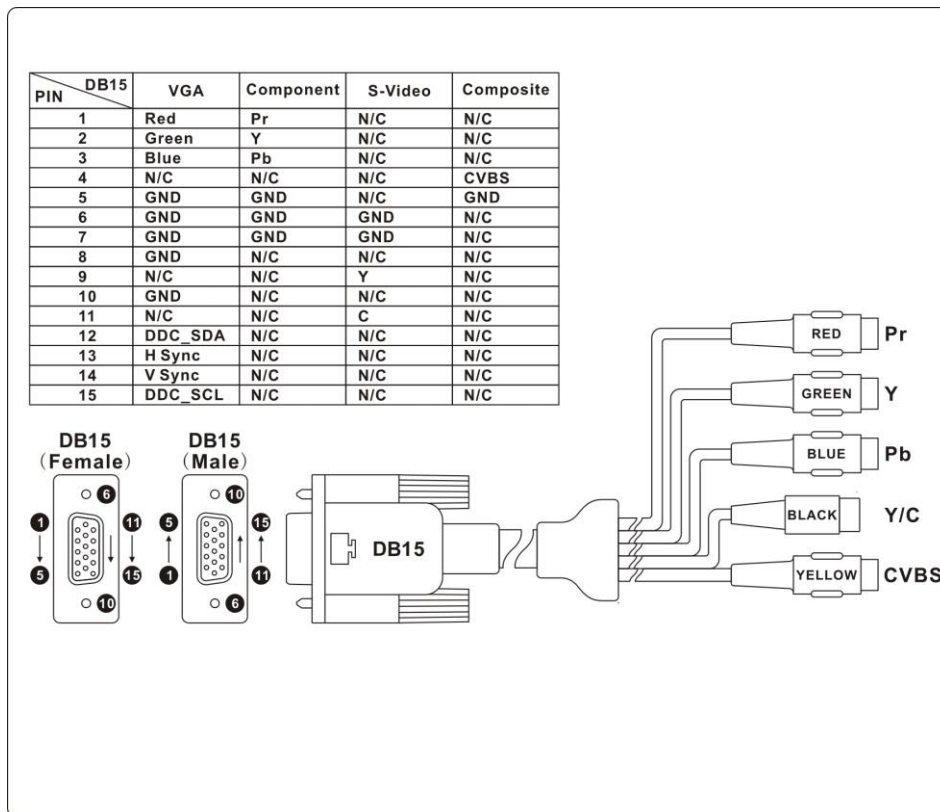

VGA input board of matrix supports the input of analog, composite video and component video; VGA output board supports the output of analog, composite video and component video. If users need input or output component video signal, they need connect DB15 male socket transfer cable (S terminal, RCA head). The two kinds of connection are different, two things should be noticed:

1. The connection of VGA input board: Support VGA, CVBS and YPbPr signal; when CVBS and YPbPr signal are needed, only three lines of DB15 male socket transfer cable terminal are useful. As shown above, the connection of YPbPr signal is Y attached to green line, Pb attached to blue line, Pr attached to red line; For CVBS signal, green line is the right one, signals can be recognized automatically, no setting is needed (VGA input port can access three signals, but one port can only attach to one signal a time).
2. The connection of VGA output board: Support VGA, CVBS and YPbPr signal; when CVBS and YPbPr signal are needed, four lines of DB15 male socket transfer cable terminal are useful. As shown above, the connection of YPbPr signal is Y attached to green line, Pb attached to blue line, Pr attached to red line; For CVBS signal, only yellow line is the right one. VGA or YPbPr signal output requires instruction setting; CVBS output has always been on, no setting is needed.

Chapter 3 Control Panel Operating Instructions

3.1 Panel description

Taking VW-VM1616 as an example, the matrix panel operating instructions is as follows.

VW-VM1616 front panel:

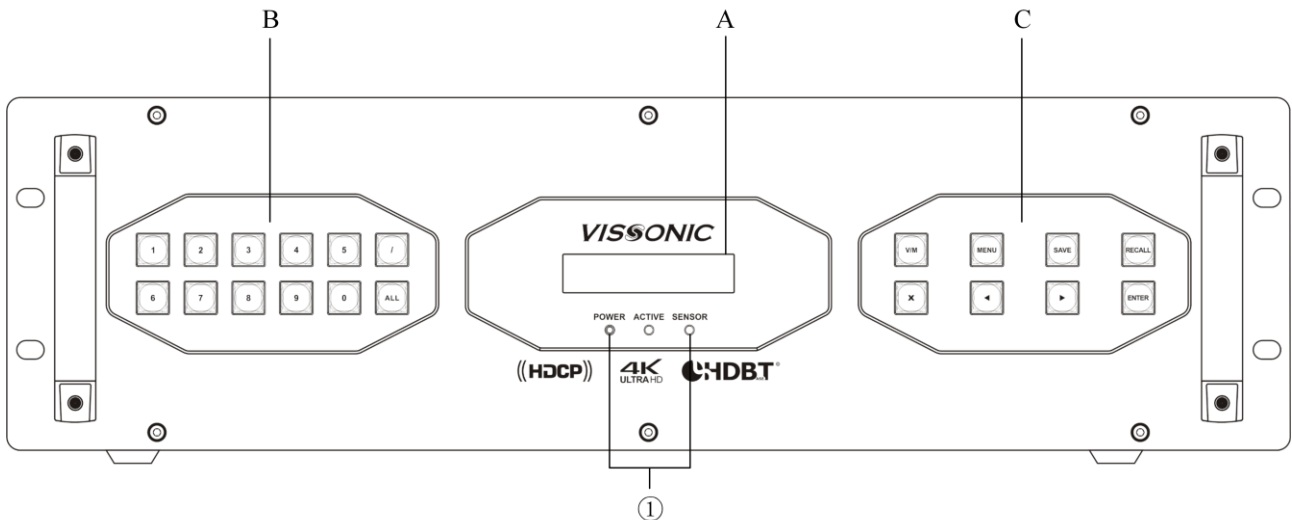

VW-VM1616 back panel:

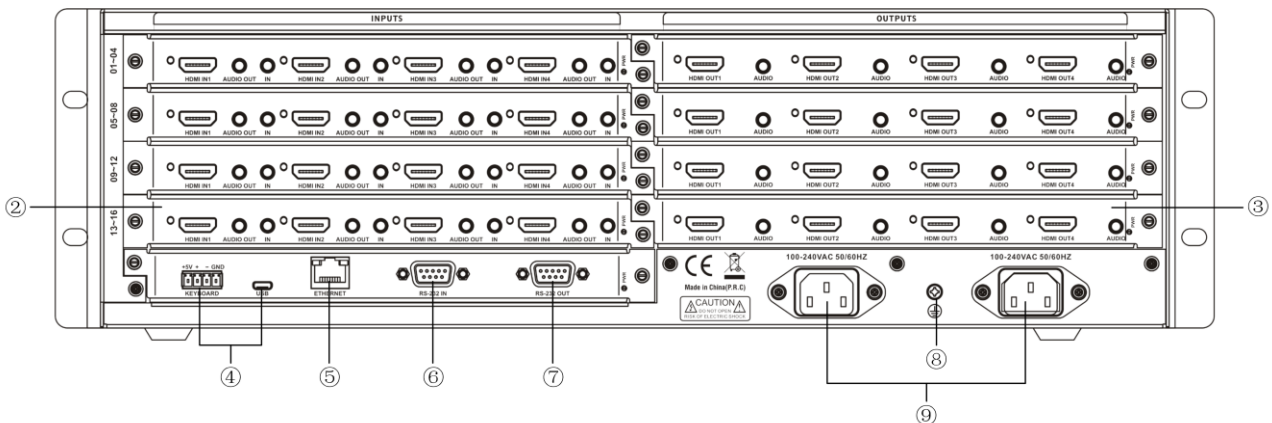

- A. **DISPLAY**—current matrix status, command input and result prompt.
- B. **CHANNEL**—input channel number and output channel number button, / button is used to select the separator of multiple channels at the same time, ALL button is used to select all output channels.
- C. **CONTROL**—change IP, V switching command, M stitching command, SAVE save scene, RECALL call scene, and left and right

menu selection buttons.

- ① **POWER**—power light
ACTIVE—state light of receiving commands
SENSOR—infrared receiving window
- ② **INPUTS**—signal input interface
 Various boards are adopted as signals' input source, providing 8/16/36/72/144 input interfaces to connect corresponding input devices.

③ **OUTPUTS**——signal output interface
 Various boards are adopted as signals' output source, providing 8/16/36/72/144 output interfaces to connect corresponding output devices.

④ **KEYBOARD**——extended keyboard interface
 One KEYBOARD interface, used together with MKB100 keyboard.

USB——reserved interface

⑤ **ETHERNET**——RJ45 network interface
 Ethernet link interface can be used to link local area network, internet and so on. Green light indicates the link is normal, sparkling orange light indicates it is receiving or sending data.

⑥ **RS-232 IN**——RS-232 serial port input
 One independent RS-232 port (DB9 female socket) can be use to link PC or central control devices to control the system.





⑦ **RS-232 OUT**——RS-232 serial port output
 One independent RS-232 port (DB9 male socket) can be use to link PC or central control devices to control the system.

⑧ **Ground jumper**

⑨ **Power interface**

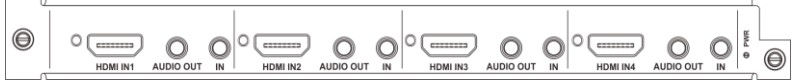
System power supports AC 100–240 V 50/60 Hz input.
 Support dual power supply redundancy.

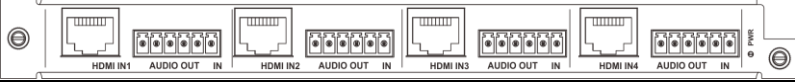
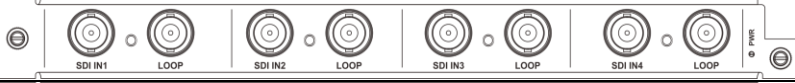
3.2 Board types

Model/Name	Appearance
VW-HM4I HDMI input board	
VW-HM2I HDMI input board (two 4K ports)	
VW-HD4I HDBaseT Seamless input board	
VW-SD4I SDI input board	
VW-VA4I VGA input board	

VW-DV4I DVI input board	
VW-SF4I optical fiber input board (single-mode/multi-mode fiber)	
VW-HM4O HDMI Seamless output board	
VW-HM2O HDMI Seamless output board (two 4K ports)	
VW-HD4O HDBaseT Seamless output board	
VW-SD4O SDI Seamless output board	
VW-DV4O DVI Seamless output board	
VW-VA4O VGA Seamless output board	
VW-SF4O optical fiber seamless output board	
VP-HM4O HDMI stitching output board	
VP-HM2O HDMI stitching output board (2 ports, 4 windows)	
VP-HM2O-4K HDMI stitching output board (2 ports, single port 4K stitching 2 window output)	
VP-DV4O DVI stitching output board (4 ports, 2 windows)	
VP-HD4O CAT5 stitching output board (4 ports, 2 windows)	
VW-PVW preview board	
VW-Con ETN5 advanced control board	

3.3 Input board

3.3.1 VW-HM4I input board function

- ◆ 4×HDMI-A ports, 8×3.5mm audio sockets;

- ◆ Maximum transmission distance can reach 35 meters;

- ◆ Hot plugging, seamless switch of audio and video together;
- ◆ 3.5 analog audio and HDMI embedded audio be input selectively;
- ◆ Digital audio de-embedding output to 3.5 audio socket;
- ◆ EDID reading function;
- ◆ HDMI 1.3a, HDCP 1.3 protocol, DVI 1.0 protocol;
- ◆ Maximum supported resolution:
HDPC: 1920×1200P@60;
HDTV: 1920×1080P@60.
- ◆ Fast seamless switching, no flickering, no black screen;
- ◆ Power-off scene switching memory protection function, unique ESD electrostatic protection function.

3.3.2 VW-HM2I input board function

- ◆ 2×HDMI-A ports, 4×3.5mm audio sockets;
- ◆ Maximum transmission distance can reach 35 meters;
- ◆ Hot plugging, seamless switch of audio and video together;
- ◆ 3.5 analog audio and HDMI embedded audio be input selectively;
- ◆ Digital audio de-embedding output to 3.5 audio socket;
- ◆ EDID reading function;
- ◆ HDMI 1.4a, HDCP 1.4 protocol, DVI 1.0 protocol;
- ◆ Maximum supported resolution: 4K×2K@30.

3.3.3 VW-HD4I CAT5 input board function

- ◆ 4 ports of high-speed RJ45, 4 ports of 6 PIN phoenix;
- ◆ Maximum transmission distance via CAT5e/6 can reach 100 meters (when 1080P@60Hz);
- ◆ Hot plugging, seamless switch of audio and video together;
- ◆ Support infrared serial input/output, combined with optional IO switch board, enable to realize infrared port switch;
- ◆ Compatible with HDBaseT protocol;

- ◆ Maximum supported resolution:
HDPC: 1920×1200P@60;
HDTV: 1920×1080P@60.

3.3.4 VW-IP2I IP input board function

- ◆ 2 ports of high-speed RJ45;
- ◆ Maximal output distance with CAT5e/6 cable 100 M;
- ◆ Support web logging in to configure the network protocol, LAN parameters, and Remote Network parameters, etc.;
- ◆ Support receiving video with fixed IP address, or automatically search for encoding devices on the network;
- ◆ Compatible with onvif, RTP, RTSP, RTCP, TCP, UDP and other network protocols;
- ◆ Compatible with G711a, G711u, G726 and ADPCM audio coding;
- ◆ Support Hikvision, Dahua, Huawei and other mainstream manufacturers cameras;
- ◆ Maximum supported resolution:
1920×1080P@60.

Note: **The IP address of the connected IP camera and the interface's local IP address should be within the same network segment.**

3.3.5 VW-SD4I input board function

- ◆ 4 BNC female ports, 4 looping out ports of BNC female;
- ◆ Hot plugging;
- ◆ Support SD/HD/3G SDI signal input;
- ◆ SDI-3G 1080p@60 frame signal transmission distance up to 100 m, compatible with HDTV;
- ◆ Support fast seamless switching, no flickering, no black screen;
- ◆ Power-off scene switching memory protection function.

3.3.6 VW-VA4I input board function

- ◆ 4 input ports of DB15, 3.5 audio base;
- ◆ Support VGA, YPbPr signal input, input signal source can be recognized automatically;
- ◆ Hot plugging, support seamless switch of audio

and video together;

- ◆ Support analog audio input;
- ◆ Maximum supported resolution:
HDPC: 1920×1080P@60;
HDTV: 1920×1080P@60.
- ◆ The color, contrast, sharpness and position of any VGA input signal can be adjusted by RS232 code;
- ◆ Support single channel restore factory settings;
- ◆ VGA input automatic correction.



Only when external video is input at VGA interface, VGA input board's 3.5mm audio port will receive audio signal.

3.3.7 VW-DV4I input board function

- ◆ 4 DVI-D ports, 3.5 audio base;
- ◆ Maximum transmission distance can reach 35 meters;
- ◆ Hot plugging, support seamless switch of audio and video together;
- ◆ Support analog audio input;
- ◆ EDID reading function;
- ◆ Compatible with HDMI 1.4a, HDCP 1.4 protocol, DVI 1.0 protocol;
- ◆ Maximum supported resolution:
HDPC: 1920×1200P@60;
HDTV: 1920×1080P@60.

3.3.8 VW-SF4I optical fiber input board function

- ◆ 4 ports of single-core optical fiber input;
- ◆ Hot plugging;
- ◆ Transmission distance with the aid of optical fiber transmitter can be 300 meters (multi-mode), and maximum transmission distance can reach 20 kilometers (single-mode);
- ◆ Optional IO switching board can realize serial port switching;
- ◆ Maximum supported resolution:
HDPC: 1920×1200P@60;
HDTV: 1920×1080P@60.

3.4 Output board

3.4.1 VW-HM4O seamless output board function

- ◆ 4 ports of HDMI-A seamless output, 4 ports of 3.5 audio base;
- ◆ Maximum transmission distance can reach 7 meters;
- ◆ Hot plugging, support seamless switch of audio and video together;
- ◆ Support analog audio and HDMI embedded audio be output together;
- ◆ EDID reading function;
- ◆ Compatible with HDMI 1.4a, HDCP 1.4 protocol, DVI 1.0 protocol;
- ◆ Maximum supported resolution:
HDPC: 1920×1200P@60;
HDTV: 1920×1080P@60.
- ◆ Fast and seamless switching, no flickering, no black screen;
- ◆ Power-off scene switching memory protection function, unique ESD electrostatic protection function.

3.4.2 VW-HM2O 4K seamless output board function

- ◆ 2 ports of HDMI-A seamless output, 2 ports of 3.5 audio base;
- ◆ Maximum transmission distance can reach 7 meters;
- ◆ Hot plugging, support seamless switch of audio and video together;
- ◆ Support analog audio and HDMI embedded audio be output together;
- ◆ EDID reading function;
- ◆ Compatible with HDMI 1.4a, HDCP 1.4 protocol, DVI 1.0 protocol;
- ◆ Maximum supported resolution: 4K×2K@30.

3.4.3 VW-HD4O CAT5 seamless output board function

- ◆ 4 ports of high-speed RJ45 seamless output, 4 ports of 6 PIN phoenix;
- ◆ Maximum transmission distance via CAT5e/6

can reach 100 meters;

- ◆ Hot plugging, support seamless switch of audio and video together;
- ◆ Support infrared serial input/output, combined with optional IO switch board, enable to realize infrared serial port switch;
- ◆ Compatible with HDBaseT protocol;
- ◆ Maximum supported resolution:
HDCP: 1920×1200P@60;
HDTV: 1920×1080P@60.

3.4.4 VW-SD40 seamless output board function

- ◆ 4 ports of SDI video signal seamless output;
- ◆ Support HD-SDI/3G-SDI signal.
- ◆ 4 ports of sdi loop out;
- ◆ 3G-SDI 1080p@60 frame signal transmission distance up to 100 m, fully compatible with HDTV;
- ◆ Hot plugging;
- ◆ Fast seamless switching, no flickering, no black screen;
- ◆ Power-off scene switching memory protection function.

3.4.5 VW-DV40 seamless output board function

- ◆ 4 ports of DVI-D seamless output, 4 ports of 3.5 analog audio output;
- ◆ Maximum transmission distance can reach 15 meters;
- ◆ Hot plugging, support seamless switch of audio and video together;
- ◆ Support analog audio output;
- ◆ EDID reading function;
- ◆ Support DVI 1.0 protocol;
- ◆ Maximum supported resolution:
HDCP: 1920×1200P@60;
HDTV: 1920×1080P@60.

3.4.6 VW-VA40 seamless output board function

- ◆ 4 ports of DB15 female output, 3.5 audio base;
- ◆ Support of outputting VGA, YPbPr signal

selectively;

- ◆ Hot plugging, support seamless switch of audio and video together;
- ◆ Support analog audio output;
- ◆ Maximum supported resolution:
HDCP: 1920×1200P@60;
HDTV: 1920×1080P@60.

3.4.7 VW-SF40 optical fiber seamless output board function

- ◆ 4 ports of single-core optical fiber output;
- ◆ Hot plugging;
- ◆ Transmission distance with the aid of optical fiber transmitter can be 300 m (multi-mode), and maximum transmission distance can reach 20 km (single-mode);
- ◆ Using optional IO switch board enables to realize serial port switch;
- ◆ Maximum supported resolution:
HDCP: 1920×1200P@60;
HDTV: 1920×1080P@60.

3.4.8 VW-STM4 streaming media output board function

- ◆ One RJ45 port of streaming media output, which can output 4 channels of video image information at the same time;
- ◆ The video resolution of each channel can reach 1080P@30fps or 720P@30/60fps;
- ◆ Apply H.264&JPEG multi-stream encoding;
- ◆ Frame rate support 1/16 to 60fps;
- ◆ Hot swap;
- ◆ Support streaming media signal and paperless system interconnection, switch matrix input signals to paperless system.

3.4.9 VP-HM40 stitching output board function

- ◆ 4 ports of HDMI stitching output;
- ◆ LED/LCD stitching function;
- ◆ Maximum resolution 1920×1200;
- ◆ Single screen can open 2 windows; signals can overlay, roam and scale arbitrarily;
- ◆ Support audio de-embedding output.

3.4.10 VP-HM2O stitching output board function

- ◆ 2 ports of HDMI stitching output;
- ◆ LED/LCD stitching function;
- ◆ Maximum resolution 1920×1200;
- ◆ Single screen can open 4 windows; signals can overlay, roam and scale arbitrarily;
- ◆ Support audio de-embedding output.

3.4.11 VP-HM2O-4K stitching output board function

- ◆ 2 ports of HDMI stitching output;
- ◆ LED/LCD stitching function;
- ◆ Maximum resolution 4K×2K;
- ◆ Single screen can open 2 windows; signals can overlay, roam and scale arbitrarily;
- ◆ Support audio de-embedding output.

3.4.12 VP-DV4O stitching output board function

- ◆ 4 ports of DVI stitching output;
- ◆ LED/LCD stitching function;
- ◆ Maximum resolution 1920×1200;
- ◆ Single screen can open 2 windows; signals can overlay, roam and scale arbitrarily;
- ◆ Support audio de-embedding output.

3.4.13 VP-DV2O stitching output board function

- ◆ 2 ports of DVI stitching output;
- ◆ LED/LCD stitching function;
- ◆ Maximum resolution 1920×1200;
- ◆ Single screen can open 4 windows; signals can overlay, roam and scale arbitrarily;
- ◆ Support audio de-embedding output.

3.4.14 VP-HD4O stitching output board function

- ◆ 4 RJ45 ports of high-speed output, 4 ports of 6 PIN phoenix;
- ◆ LED/LCD stitching function;
- ◆ Maximum transmission distance via CAT5e/6 can reach 100 m;

- ◆ Hot plugging;
- ◆ Support infrared serial output, combined with optional IO switch board, enable to realize infrared serial port switch;
- ◆ Compatible with HDBaseT protocol;
- ◆ Support 4-channel twisted pair seamless output, support RS232, IR interface of the board, maximum resolution support 1920×1200@60 Hz. The board is used in conjunction with VIS-HE7-R or VIS-HE10-R to achieve 100 m transmission of input signals (with the optional POC power supply, it can realize remote power supply to the transmission extender);
- ◆ Single screen can open 2 windows; signals can overlay, roam and scale arbitrarily.

3.4.15 VP-HD2O stitching output board function

- ◆ 2 RJ45 ports of high-speed output, 2 ports of 6 PIN phoenix;
- ◆ LED/LCD stitching function;
- ◆ Maximum transmission distance via CAT5e/6 can reach 100 m;
- ◆ Hot plugging;
- ◆ Support infrared serial output, combined with optional IO switch board, enable to realize infrared serial port switch;
- ◆ Compatible with HDBaseT protocol;
- ◆ Support 2-channel twisted pair seamless output, support RS232, IR interface of the board, maximum resolution support 1920×1200@60 Hz. The board is used in conjunction with VIS-HE7-R or VIS-HE10-R to achieve 100 m transmission of input signals (with the optional POE power supply, it can realize remote power supply to the transmission extender);
- ◆ Single screen can open 4 windows; signals can overlay, roam and scale arbitrarily.

3.5 Preview board

3.5.1 VW-PVW preview board function

- ◆ One RJ45 port of preview output, can view 4

channels video image information in groups at the same time;

- ◆ Video resolution of each channel up to 1080P@30 fps or 720P@30/60 fps;
- ◆ Apply H.264 & JPEG multi-stream encoding, frame rate supports 1/16 to 60 fps;
- ◆ Hot swap;
- ◆ Support switching control from preview channel to output channel.



The preview board is connected to the output board slot of the matrix, and a matrix supports a preview board.

3.6 Control board

3.6.1 VW-Con ETN5 advanced control board function

- ◆ Two DB9 fully functional serial ports, enabling to control multiple peripherals and to receive commands;
- ◆ One USB reserved interface;
- ◆ One RJ45 interface, enabling to download, upgrade controlled programming and to query information;
- ◆ One 4Pin phoenix-head keyboard interface, enabling to operate with keyboards;
- ◆ One 3Pin phoenix-head serial port, enabling to output debugging information and to receive commands;
- ◆ Hot plugging;
- ◆ Support controlled programming.

3.7 Specification and Parameter

3.7.1 VW-HM4I and VW-HM4O

Model	VW-HM4I	VW-HM4O
Specifications		
Protocol	HDMI 1.4a, HDCP 1.4 protocol, DVI 1.0 protocol.	
Video		
Gain	0dB	
Pixel bandwidth	165MHz, all-digital	
Interface bandwidth	2.25Gbps, all-digital (6.75Gbps in all, each color is 2.25Gbps)	
Supported resolution	800x600@60,1024x768@60,1280x720@60,1280x768@60, 1280x800@60, 1280x960@60, 1280x1024@60,1360x768@60,1366x768@60,1440x900@60,1600x900@60,1600x1200@60,1920x1080@25,1920x1080P@30,1920x1200P@60,1920x1080P@60,1920x1080i@50,1920X1080i@60	
Clock Jitter	<0.15 Tbit	
Rise time	<0.3Tbit (20%--80%)	
Fall time	<0.3Tbit (20%--80%)	
Maximum transmission delay	5nS(±1nS)	
Interface	Four-way HDMI-A interface, four-way 3.5mm audio base	
Signal strength	T.M.D.S. +/- 0.4Vpp	
Minimum/maximum signal level	T.M.D.S. 2.9V/3.3V	
Impedance	50 Ω	
EDID	Default EDID and reading function	N/A
Maximum DC bias error	15mV	
Suggested maximum input/output transmission distance	Maximum transmission distance is 35 meters with 1600x1200@60 (recommend to use certified HDMI dedicated wires, such as Molex TM wire)	Maximum transmission distance is 7 meters with 1600x1200@60 (recommend to use certified HDMI dedicated wires, such as Molex TM wire)
Product weight	About 0.5KG	About 0.5KG
Maximum consumption	15W	15W

3.7.2 VW-HM2I and VW-HM2O

Model	VW-HM2I	VW-HM2O
Specifications		
Protocol	HDMI 1.4, HDCP 1.4 protocol, DVI 1.0 protocol;	
Video		
Gain	0dB	
Pixel bandwidth	297MHz, all-digital	
Interface bandwidth	4.5Gbps, all-digital (13.5Gbps in all, each color is 4.5Gbps)	

Model Specifications	VW-HM2I	VW-HM2O
Supported resolution	800x600@60,1024x768@60,1280x720@60,1280x768@60, 1280x800@60, 1280x960@60, 1280x1024@60,1360x768@60,1366x768@60,1440x900@60,1600x900@60,1600x1200@60,1920x1080@25,1920x1080P@30,1920x1200P@60,1920x1080P@60,1920x1080i@50,1920X1080i@60,4Kx2K@30Hz	
Clock Jitter	<0.15 Tbit	
Rise time	<0.3Tbit (20%--80%)	
Fall time	<0.3Tbit (20%--80%)	
Maximum transmission delay	5nS(±1nS)	
Interface	Two-way HDMI-A interface, 3.5mm audio output;	
Signal strength	T.M.D.S. +/- 0.4Vpp	
Minimum/maximum signal level	T.M.D.S. 2.9V/3.3V	
Impedance	50 Ω	
EDID	N/A	
Maximum DC bias error	15mV	
Suggested maximum input/output transmission distance	Maximum transmission distance is 35 meters with 1600x1200@60 (recommend to use certified HDMI dedicated wires, such as Molex TM wire)	Maximum transmission distance is 7 meters with 1600x1200@60 (recommend to use certified HDMI dedicated wires, such as Molex TM wire)
Product weight	About 0.5KG	About 0.5KG
Maximum consumption	20W	20W

3.7.3 VW-DV4I and VW-DV4O

Model Specifications	VW-DV4I	VW-DV4O
Protocol	DVI 1.0 protocol	
Video		
Gain	0dB	
Pixel bandwidth	165MHz, all-digital	165MHz, all-digital or analog
Interface bandwidth	2.25Gbps, all-digital (6.75Gbps in all, each color is 2.25Gbps)	2.25Gbps all-digital or 350MHz analog
Supported resolution	800x600@60,1024x768@60,1280x720@60,1280x768@60,1280x800@60,1280x960@60,1280x1024@60,1360x768@60,1366x768@60,1440x900@60,1600x900@60,1600x1200@60,1920x1200P@60,1920x1080P@60, 1920x1080i@50,1920X1080i@60;	
Clock Jitter	<0.15 Tbit	
Rise time	<0.3Tbit (20%--80%)	
Fall time	<0.3Tbit (20%--80%)	
Maximum transmission delay	5nS(±1nS)	

Model Specifications	VW-DV4I	VW-DV4O
Interface	Four-way DVI-D female interface, four-way 3.5mm audio base	Four-way DVI-I female interface, four-way 3.5mm audio base
Signal strength	T.M.D.S. +/- 0.4Vpp	
Minimum/maximum signal level	T.M.D.S. 2.9V/3.3V	
Impedance	50 Ω	
EDID	Default EDID and reading function	N/A
Maximum DC bias error	15mV	
Suggested maximum input/output transmission distance	Maximum transmission distance is 35 meters with 1600x1200@60 (recommend to use certified HDMI dedicated wires, such as Molex TM wire)	Maximum transmission distance is 7 meters with 1600x1200@60 (recommend to use certified HDMI dedicated wires, such as Molex TM wire)
Product weight	About 0.5KG	About 0.5KG
Maximum consumption	15W	15W

3.7.4 VW-HD4I and VW-HD4O

Model Specifications	VW-HD4I	VW-HD4O
Link input/output		
Interface	Four-way high-speed base and four-way 6PIN phoenix base	
Supported protocol	HDBaseT protocol	
Pixel bandwidth	165MHz, all-digital	
Interface bandwidth	2.25Gbps, all-digital (6.75Gbps in all, each color is 2.25Gbps)	
Supported resolution	800x600@60,1024x768@60,1280x720@60,1280x768@60,1280x800@60,1280x960@60,1280x1024@60,1360x768@60,1366x768@60,1440x900@60,1600x900@60,1600x1200@60,1920x1200P@60,1920x1080P@60,1920x1080i@50,1920x1080i@60;	
Signal type	High-speed differential signal defined in HDBaseT protocol	
Cable transmission power	POC power supply (+48V), it should be used with our company CAT5 series transmitter which can provide power supply via cables.	POC power supply (+48V), it should be used with our company CAT5 series receiver which can provide power supply via cables.
Impedance	50 Ω	
EDID	Default EDID	N/A
Maximum DC bias error	15mV	
Suggested maximum input/output transmission distance	Maximum transmission distance is 100 meters with 1600x1200@60 (recommend to use NEXANS CAT5e/6 dedicated wires)	
Product weight	About 0.5KG	About 0.5KG
Maximum consumption	27W	22W

3.7.5 VW-VA4I and VW-VA4O

Model Specifications		VW-VA4I	VW-VA4O	
Interface		DB15 interface, 3.5mm audio base		
Supported resolution	Component video YPbPr	Input board: 480i/NTSC, 480P/NTSC, 576i/PAL, 576P/PAL, 1280x720@50, 1280x720@60, 1920x1080i@50, 1920X1080P@60; Output board: 1280x720@60, 1920X1080P@60;		
	VGA video	Input board: 800x600@60,1024x768@60,1280x720@60,1280x768@60,1280x800@60,1280x960@60,1280x1024@60,1360x768@60,1360x1024@60,1366x768@60,1440x900@60,1400x1050@60,1600x900@60,1600x1200@60,1680x1050@60,1920X1080P@60; Output board: 800x600@60,1024x768@60,1280x720@60,1280x768@60,1280x800@60,1280x960@60,1280x1024@60,1360x768@60,1366x768@60,1440x900@60,1600x900@60,1600x1200@60,1920x1200P@60,1920X1080P@60;		
Gain		0dB	0 dB	0 dB
Bandwidth		150MHz @ -3dB	350MHz @ -3dB	380 MHz
Differential phase error		0.1°,3.58-4.43 MHz	0.1°,3.58-4.43 MHz	
Differential gain error		0.1% , 3.58-4.43 MHz	0.1%, 3.58-4.43 MHz	
Signal strength		1V p-p: composite video (CVBS)	1V p-p: (Y in component video) 0.3Vp-p: (PbPr/CbCr in component video)	0.63V p-p -- 0.9 V p-p
Minimum/maximum level		Analog signal: -2V/+2V	Analog signal: -2V/+2V	RGB signal: 0V/1.0V HV signal: 0V/5.0V
Impedance		75 Ω	75Ω	75Ω
Return loss		<-30dB@5MHz	<-30dB@5MHz	<-30dB@5MHz
Product weight		About 0.5KG		
Maximum consumption		20W		

3.7.6 VW-SD4I and VW-SD4O

Model Specifications		VW-SD4I	VW-SD4O
Interface		Four-way BNC input/output, four-way BNC looping out	
Supported protocol		SMPTE 425M, SMPTE 424M, SMPTE 292M	
Pixel bandwidth		2.970Gb/s, 1.485Gb/s	
Supported resolution		1920x1080@25,1920x1080P@30,1280x720@60,1920X1080P@60,1920x1080i@50, 1920X1080i@60;	
Supported format		HD-SDI, 3G-SDI	
Product weight		About 0.5KG	

Model Specifications	VW-SD4I	VW-SD4O
Maximum consumption	20W	

3.7.7 VW-SF4I and VW-SF4O

Model Specifications	VW-SF4I	VW-SF4O
Interface	Four-way high-speed single-core SC optical fiber interface	
Video		
Optical fiber interface	SC connector	
Optical fiber type	Multimode/Single Mode(optional)	
Wavelength	1310 nm	
Interface bandwidth	10 Gbps	
Clock Jitter	<0.15 Tbit	
Rise time	<0.3Tbit (20%--80%)	
Fall time	<0.3Tbit (20%--80%)	
Suggested maximum input transmission distance	OM3 multimode optical fiber: <300 meters, single mode optical fiber: 2~20kilometers, 1920x1080p@60	
Supported resolution	800x600@60,1024x768@60,1280x720@60,1280x768@60,1280x800@60,1280x960@60,1280x1024@60,1360x768@60,1366x768@60,1440x900@60,1600x900@60,1600x1200@60,1920x1200P@60,1920X1080P@60,1920x1080i@50,1920X1080i@60;	
Product weight	About 0.5KG	
Maximum consumption	20W	

3.7.8 VW-IP2I

Model Specifications	VW-IP2I
Network protocol	
Onvif, RTP, RTCP, RTSP, TCP, UDP	
Video	
Network interface bandwidth	100M
video compression	H.264 MainProfile/H.264 Baseline Profile/H.264 HighProfile
audio compression	G711a, G711u, G726, ADPCM
control protocol	Support standard protocol Onvif
Maximum Transmission Delay	100 ms (depending on encoding delay and network transmission delay)
IP parameters	Port1 default IP: 192.168.1.100 Port3 default IP: 192.168.1.200

Model	VW-IP2I
Specifications	
Support resolution and frame rate	1920×1080@60Hz,1920×1080@30Hz,1920×1080@25Hz,1280×720@60Hz,1280×1024@60Hz,1280×960@60Hz,704×576@60Hz,704×576@30Hz,704×576@25Hz,704×480@60Hz,704×480@30Hz,704×480@25Hz,352×288@60Hz,352×288@30Hz,352×288@25Hz;
Recommended maximum input distance	100 m
Weight	0.5 kg
Consumption	25 W

3.7.9 VP-HM40

Model	VP-HM40
Specifications	
Protocol	HDMI 1.4a, HDCP 1.4 protocol, DVI 1.0 protocol.
Video	
Gain	0dB
Pixel bandwidth	165MHz, all-digital
Interface bandwidth	2.25Gbps, all-digital (6.75Gbps in all, each color is 2.25Gbps)
Supported resolution	800x600@60,1024x768@60,1280x720@60,1280x768@60,1280x800@60,1280x960@60,1280x1024@60,1360x768@60,1366x768@60,1440x900@60,1600x900@60,1600x1200@60,1920x1080@25,1920x1080P@30,1920x1200P@60,1920X1080P@60.
control scale	A single unit can control a maximum of 144 screens and multiple groups of screens, and can save 128 pre-plans
Clock Jitter	<0.15 Tbit
Number of windows	2 windows can be opened on a single screen, signals can be superimposed, roamed, and zoomed arbitrarily.
Rise time	<0.3Tbit (20%--80%)
Fall time	<0.3Tbit (20%--80%)
Maximum transmission delay	5nS(±1nS)
Interface	Four-way DVI-D interfaces
Signal strength	T.M.D.S. +/- 0.4Vpp
Minimum/maximum signal level	T.M.D.S. 2.9V/3.3V
Impedance	50 Ω
EDID	N/A
Maximum DC bias error	15mV
Suggested maximum input/output transmission distance	Maximum transmission distance is 7 meters with 1600x1200@60 (recommend to use HDMI dedicated wires, such as Molex TM wire)
Product weight	About 0.5KG
Maximum consumption	15W

3.7.10 VP-HM20

Model	VP-HM20
Specifications	
Protocol	
HDMI 1.4a, HDCP 1.4 protocol, DVI 1.0 protocol.	
Video	
Gain	0dB
Pixel bandwidth	165MHz, all-digital
Interface bandwidth	2.25Gbps, all-digital (6.75Gbps in all, each color is 2.25Gbps)
Supported resolution	800x600@60,1024x768@60,1280x720@60,1280x768@60,1280x800@60,1280x960@60,1280x1024@60,1360x768@60,1366x768@60,1440x900@60,1600x900@60,1600x1200@60,1920x1080@25,1920x1080P@30,1920x1200P@60,1920X1080P@60.
control scale	A single unit can control a maximum of 144 screens and multiple groups of screens, and can save 128 pre-plans
Clock Jitter	<0.15 Tbit
Number of windows	4 windows can be opened on a single screen, signals can be superimposed, roamed, and zoomed arbitrarily
Rise time	<0.3Tbit (20%--80%)
Fall time	<0.3Tbit (20%--80%)
Maximum transmission delay	5nS(±1nS)
Interface	two-way DVI-D interfaces
Signal strength	T.M.D.S. +/- 0.4Vpp
Minimum/maximum signal level	T.M.D.S.
Impedance	50 Ω
EDID	N/A
Maximum DC bias error	15mV
Suggested maximum input/output transmission distance	Maximum transmission distance is 7 meters with 1600x1200@60 (recommend to use HDMI dedicated wires, such as Molex TM wire)
Product weight	About 0.5KG
Maximum consumption	15W

3.7.11 VP-HM20-4K

Model	VP-HM20-4K
Specifications	
Protocol	
HDMI 1.4a, HDCP 1.4 protocol, DVI 1.0 protocol.	
Video	
Gain	0dB
Pixel bandwidth	165MHz, all-digital

Model Specifications	VP-HM20-4K
Interface bandwidth	2.25Gbps, all-digital (6.75Gbps in all, each color is 2.25Gbps)
Supported resolution	800x600@60,1024x768@60,1280x720@60,1280x768@60,1280x800@60,1280x960@60,1280x1024@60,1360x768@60,1366x768@60,1440x900@60,1600x900@60,1600x1200@60,1920x1080@25,1920x1080P@30,1920x1200P@60,1920X1080P@60,3120X2160@30.
control scale	A single unit can control a maximum of 144 screens and multiple groups of screens, and can save 128 pre-plans
Clock Jitter	<0.15 Tbit
Number of windows	2 windows can be opened on a single screen, signals can be superimposed, roamed, and zoomed arbitrarily
Rise time	<0.3Tbit (20%--80%)
Fall time	<0.3Tbit (20%--80%)
Maximum transmission delay	5nS(±1nS)
Interface	two-way DVI-D interfaces
Signal strength	T.M.D.S. +/- 0.4Vpp
Minimum/maximum signal level	T.M.D.S.
Impedance	50 Ω
EDID	N/A
Maximum DC bias error	15mV
Suggested maximum input/output transmission distance	Maximum transmission distance is 7 meters with 1600x1200@60 (recommend to use HDMI dedicated wires, such as Molex TM wire)
Product weight	About 0.5KG
Maximum consumption	15W

3.7.12 VP-DV40

Model specifications	VP-DV40
Protocol	
DVI 1.0 protocol	
Video	
Gain	0dB
Pixel bandwidth	165MHz, all-digital
Interface bandwidth	2.25Gbps all-digital (6.75Gbps in all, each color is 2.25Gbps)
Supported resolution	800x600@60,1024x768@60,1280x720@60,1280x768@60,1280x800@60,1280x960@60,1280x1024@60,1360x768@60,1366x768@60,1440x900@60,1600x900@60,1600x1200@60,1920x1200P@60,1920X1080P@60.
control scale	A single unit can control a maximum of 288 screens and multiple groups of screens, and can save 128 pre-plans
Clock Jitter	<0.15 Tbit

Model specifications	VP-DV40
Number of windows	2 windows can be opened on a single screen, signals can be superimposed, roamed, and zoomed arbitrarily
Rise time	<0.3Tbit (20%--80%)
Fall time	<0.3Tbit (20%--80%)
Maximum transmission delay	5nS(±1nS)
Interface	Four-way DVI-D interface
Signal strength	T.M.D.S. +/- 0.4Vpp
Minimum/maximum signal level	T.M.D.S. 2.9V/3.3V
Impedance	50 Ω
EDID	N/A
Maximum DC bias error	15mV
Suggested maximum input/output transmission distance	Maximum transmission distance is 7 meters with 1600x1200@60 (recommend to use DVI dedicated wires,such as Molex TM wire)
Product weight	About 0.5KG
Maximum consumption	15W

3.7.13 VP-DV20

Model specifications	VP-DV20
Protocol	
DVI 1.0 protocol	
Video	
Gain	0dB
Pixel bandwidth	165MHz, all-digital
Interface bandwidth	2.25Gbps all-digital (6.75Gbps in all, each color is 2.25Gbps)
Supported resolution	800x600@60,1024x768@60,1280x720@60,1280x768@60,1280x800@60,1280x960@60,1280x1024@60,1360x768@60,1366x768@60,1440x900@60,1600x900@60,1600x1200@60,1920x1200P@60,1920X1080P@60.
control scale	A single unit can control a maximum of 288 screens and multiple groups of screens, and can save 128 pre-plans
Clock Jitter	<0.15 Tbit
Number of windows	4 windows can be opened on a single screen, signals can be superimposed, roamed, and zoomed arbitrarily
Rise time	<0.3Tbit (20%--80%)
Fall time	<0.3Tbit (20%--80%)
Maximum transmission delay	5nS(±1nS)
Interface	two-way DVI-D interface
Signal strength	T.M.D.S. +/- 0.4Vpp

Model specifications	VP-DV20
Minimum/maximum signal level	T.M.D.S. 2.9V/3.3V
Impedance	50 Ω
EDID	N/A
Maximum DC bias error	15mV
Suggested maximum input/output transmission distance	Maximum transmission distance is 7 meters with 1600x1200@60 (recommend to use DVI dedicated wires,such as Molex TM wire)
Product weight	About 0.5KG
Maximum consumption	15W

3.7.14 VP-HD40

Model Specifications	VP-HD40
Link input/output	
Interface	4 High-speed RJ45 ports and 4 6PIN phoenix ports
Video	
Supported protocol	HDBaseT protocol
Pixel bandwidth	165MHz, all-digital
Interface bandwidth	2.25Gbps, all-digital (6.75Gbps in all, each color is 2.25Gbps)
Supported resolution	800x600@60,1024x768@60,1280x720@60,1280x768@60,1280x800@60,1280x960@60,1280x1024@60,1360x768@60,1366x768@60,1440x900@60,1600x900@60,1600x1200@60,1920x1200P@60,1920X1080P@60.
control scale	A single unit can control a maximum of 288 screens and multiple groups of screens, and can save 128 pre-plans
Number of windows	2 windows can be opened on a single screen, signals can be superimposed, roamed, and zoomed arbitrarily
Signal type	High-speed differential signal defined in HDBaseT protocol
Cable transmission power	POC power supply (+48V), it should be used with our company CAT5 series transmitter which can provide power supply via cables.
Impedance	50 Ω
EDID	N/A
Maximum DC bias error	15mV
Suggested maximum input/output transmission distance	Maximum transmission distance is 100 meters with 1600x1200@60 (recommend to use NEXANS CAT5e/6 dedicated wires)
Product weight	About 0.5KG
Maximum consumption	22W

3.7.15 VP-HD20

Model Specifications	VP-HD20
Link input/output	

Model	VP-HD20
Specifications	
Interface	2 High-speed RJ45 ports and 2 6PIN phoenix ports
Video	
Supported protocol	HDBaseT protocol
Pixel bandwidth	165MHz, all-digital
Interface bandwidth	2.25Gbps, all-digital (6.75Gbps in all, each color is 2.25Gbps)
Supported resolution	800x600@60,1024x768@60,1280x720@60,1280x768@60,1280x800@60,1280x960@60,1280x1024@60,1360x768@60,1366x768@60,1600x900@60.
control scale	A single unit can control a maximum of 144 screens and multiple groups of screens, and can save 128 pre-plans
Number of windows	4 windows can be opened on a single screen, signals can be superimposed, roamed, and zoomed arbitrarily
Signal type	High-speed differential signal defined in HDBaseT protocol
Cable transmission power	POC power supply (+48V), it should be used with our company CAT5 series transmitter which can provide power supply via cables.
Impedance	50 Ω
EDID	N/A
Maximum DC bias error	15mV
Suggested maximum input/output transmission distance	Maximum transmission distance is 100 meters with 1600x1200@60 (recommend to use NEXANS CAT5e/6 dedicated wires)
Product weight	About 0.5KG
Maximum consumption	22W

3.7.16 VW-PVW

Model	VW-PVW
Specifications	
Video	
Network interface band width	100M
Video Compress	H.264 and JPEG Multi-stream encoding
Max. transmission delay	100ms (determined by the encoding delay and network transmission delay)
IP parameters	Static IP Default IP: 192.168.1.163, Port: 5000.
Supported Resolutions and frame rate	1920×1080@30Hz; 1280x720@60fps; 1280x720@30fps;
Recommended Max. Input Distance	100m
Product weight	About 0.5KG
Maximum consumption	15W

3.7.17 VW-VM0808/1616/3636/7272/144144

Model	VW-VM0808	VW-VM1616	VW-VM3636	VW-VM7272	VW-VM144144
Specifications					
Interface					
Number of input boards/input channels	2/8	4/16	9/36	18/72	36/144
Number of output boards/output channels	2/8	4/16	9/36	18/72	36/144
Supported input board type	VW-HM4I, VW-HM2I, VW-HD4I, VW-IP2I, VW-SD4I, VW-VA4I, VW-DV4I, VW-SF4I.				
Supported seamless output board type	VW-HM4O, VW-HM2O, VW-HD4O, VW-SD4O, VW-DV4O, VW-VA4O, VW-SF4O, VW-STM4, VW-PVW.				
Supported stitching output board type	VP-HM4O, VP-HM2O, VP-HM2O-4K, VP-DV4O, VP-DV2O, VP-HD4O, VP-HD2O.				
Interface bandwidth	13.5 Gbps				
Serial port control					
Serial control interface	RS-232, 9 pin female D type interface and 9 pin male D type interface				
Baud rate and protocol	Baud rate: 9600, data bits: 8 bits, stop bits: 1 bit, no parity check bit				
Serial control interface structure	9 pin female D type interface : 2 = TX, 3 = RX, 5 = GND; 9 pin male D type interface : 2 = RX, 3 =TX, 5 = GND.				
KEYBOARD control interface					
Keyboard control interface	Four-way 3.8mm phoenix interface				
Operation method	To use with extended keyboard MCP100				
Keyboard control interface structure	+5V=DC5V , += DATA+, -=DATA- GND = signal ground				
Ethernet control					
Ethernet control interface	RJ-45 female interface				
Ethernet control protocol	TCP/IP				
Ethernet control speed rate	Adaptive 10M/100M, full-duplex or half-duplex				
Specifications					
System power	100VAC ~ 240VAC, 50/60 Hz, International adaptive power				
Storage, work temperature	0 ~ +50°C				
Storage, work humidity	20% ~ 70%				
Chassis size	2U	3U	7U	12U	24
Product weight (without boards)	About 5kg	About 7kg	About 16kg	About 29kg	About 80kg
Full power (without boards)	About 18W		About 30W		About 70W
Size	445x400x88	445x400x132	445x400x310	445x400x532	483x400x1043

Model	VW-VM0808	VW-VM1616	VW-VM3636	VW-VM7272	VW-VM144144
Specifications					
Mean time between failures	30,000 hours				
Quality guarantee	One year warranty and lifetime maintenance				

3.8 Front Panel Operation

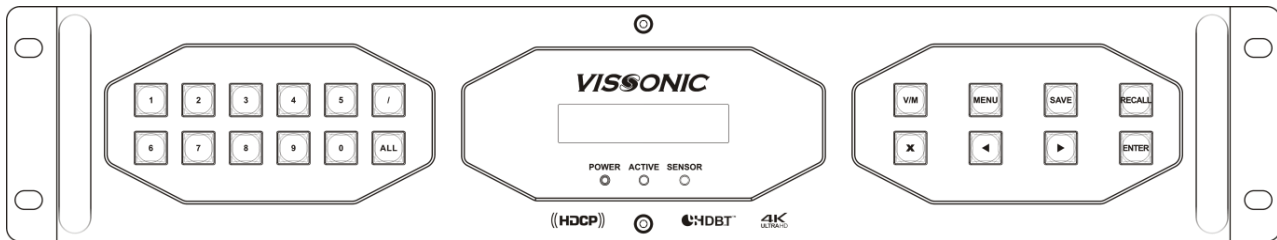

- **Seamless switching operation** (need seamless output board VW-HM40, VW-DV40, VW-HD40, VW-VA40, VW-SF40 or VW-SD40)

Sample 1. Switch input 1 to the output 2

Sequencing Pressing button	LCD display	Note
1	1	Select the input 1
V/M	1V	press 1 times and display "V" for matrix switching action
2	1V2	Select output 2
ENTER	Switch OK!	Confirm. If there are no input board, the LCD display "Not online!"

Sample 2. Switch input 1 to the output 2 and output 3

Sequencing Pressing button	LCD display	Note
1	1	Select the input 1
V/M	1V	press 1 times and display "V" for matrix switching action
2	1V2	Select output 2
/	1V2/	Press"/" button
3	1V2/3	Select output 3
ENTER	Switch OK!	Confirm. If there are no input board, the LCD display "Not online!"

Sample 3. Switch the input 1 to all output

Sequencing Pressing button	LCD display	Note
1	1	Select the input 1
ALL	1All.	Switch finish.

NOTE. Above operation is only valid on the seamless output board.

- **Video wall output board** (need video wall output board model: VP-HM4O, VP-DV4O, VP-HD4O, VP-VA4O, VP-SF4O or VP-SD4O)

The button ‘V/M’ is the switching type button, pressing 1 time and displaying ‘V’ on LCD is seamless output switching(need seamless output board), pressing 2 times and displaying ‘M’ on LCD is switching the inputs to the windows(need video wall output board).

As shown in the picture, there are five windows with window ID numbers 1, 2, 3, 4, and 5 on "Screen Wall1".

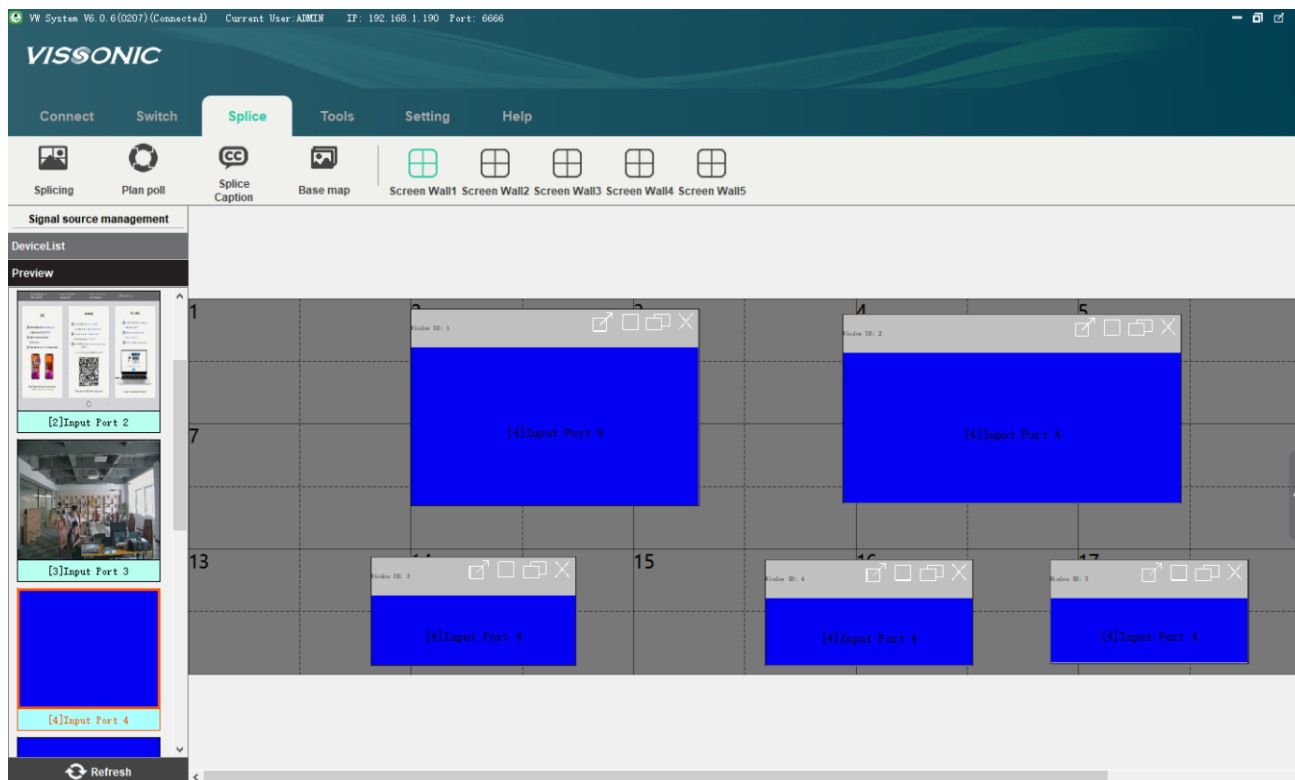

For example, we need to switch input 1 to the “window ID:5” on “Wall1”

Sequencing Pressing button	LCD display	Note
1	1	Select input 1
V/M	1V	Press one time is V for matrix switch
V/M	1M	Press one more time for video wall switching
1	1M1	Select the NO.1 Video wall
/	1M1/5	Press the symbol “/”
5	1M1/5	Select window ID 5
ENTER	Switch OK!	Confirm and finish switching.

NOTE: It is only for the video wall output board.

- **SAVE and Call the profiles**

1. Save the seamless output plan (need seamless output board), max. 10 plans, corresponding to thee button 0~9.

Sequencing Pressing button	LCD display	Note
SAVE	Save Switch Plan	

2	Save Switch Switch OK!	Save the plan 2 successful.
---	------------------------	-----------------------------

2. Call the seamless output plan (need seamless output board).

Sequencing Pressing buttons	LCD display	Note
RECALL	Recall Switch Plan	
2	Recall Switch Switch OK!	Call plan2 successful.

3. Save the video wall output plan.

Sequencing Pressing button	LCD display	Note
SAVE	Save Switch Plan	Pressing 1 time, save the seamless switching plan
SAVE	Save PJ Wall: Plan:	Pressing one more time to save the video wall plan
1	Save PJ Wall: 1 Plan:	Select the "Video wall 1"
1	Switch OK! Wall: 1 Plan:1	Select the to save on "Plan1"

4. Call the Video Wall output board status

Sequencing Pressing button	LCD display	Note
RECALL	Recall Switch Plan	Pressing 1 time, call the seamless switching plan
RECALL	Recall PJ Wall: Plan:	Pressing one more time to call the video wall plan
1	Recall PJ Wall:1 Plan:	Select the "Video wall 1"
1	Switch OK! Wall: 1 Plan:1	Select the to call on "Plan1"

● IP inquiry and setting



1. Inquiry the network parameter

Sequencing Pressing button	LCD display	Note
IP	IP SETTING 192.168.001.190	Display IP address
IP	PORT SETTING 6666	Display IP port no.
IP	GATEWAY SET 192.168.001.001	Display Gateway
IP	SubnetMask SET 255.255.255.000	Display SubnetMask

2. Revise the network parameter

For example, revised the IP address 192.168.001.190 as 192.168.001.180.

Sequencing Pressing button	LCD display	Note
----------------------------	-------------	------

IP	IP SETTING 192.168.001.190	Display IP address
◀		Enter revising mode and display revising symbol
◀ or ▶		Move the revising symbol to the number that you want to revise it.
8		Input the number
ENTER	Set Succeed!	Set successful

Revising the port no., Gateway, Subnet Mask is the same operation. Enter the corresponding menu and press ◀ to revise it.

Note:

1. Revised the network parameter and need to reboot the matrix to be accepted.
2. The network parameter for GUI interface need to be revised on the network interface only, but not by front button.

Chapter 4 Instructions

4.1 X9 processor instructions

Serial port protocol: baud rate: 9600, data bits: 8, stop bits: 1, parity bits: none

Ethernet: protocol: TCP, IP: 192.168.1.190, PORT: 6666

Meanings of instructions:

[X1], [X2]... [Xn] represents the corresponding input port;

[Y1], [Y2]... [Yn] represents the corresponding output port;

[TX1], [TX2]... [TXn] represents the corresponding input port's serial port/infrared transmitter channel;

[RX1], [RX2]... [RXn] represents the corresponding input port's serial port/infrared receiver channel; [TY1], [TY2]...

[TYn] represents the corresponding output port's serial port/infrared transmitter channel;

[RY1], [RY2]... [RYn] represents the corresponding output port's serial port/infrared receiver channel;

H represents Arabic numerals; n in the number of the corresponding model's input/output interface, such as VW-VM7272, the maximum value of n is 72.



[] of [x] in the following instruction list is annotation, in practice, it should be removed. For example,

\$[x]AudioA! should be \$8AudioA! in practice.

Instructions (pc-->X9)	Functions	Returned information	Examples
System instructions			
/:BellOff;	Close buzzer	<Closed The Bell.>	/:BellOff;
/:BellOn;	Open buzzer	<Opened The Bell.>	/:BellOn;
/:MessageOff;	Close serial port return, only few characters such as SWITCH or OK! is allowed	<Closed The Message Return.>	/:MessageOff;
/:MessageOn;	Open serial port return	<Enabled The Message Return.>	/:MessageOn;
/:HeartBeat;	PC software heartbeat	<HeartBeat>	/:HeartBeat;
\$Default!	Control board restore default (control board reset and restart)	None	\$Default!
\$(X1)DefaultIn!	Restore channel [X1] default input	<Set Succeed!>	\$1DefaultIn!
\$(Y1)DefaultOut!	Restore channel [Y1] default output	<Set Succeed!>	\$1DefaultOut!
\$AllDefaultIn!	Restore all default input	<Set Succeed!>	\$AllDefaultIn!
\$AllDefaultOut!	Restore all default output	<Set Succeed!>	\$AllDefaultOut!
Status [Y1].	Query channel [X1] output current status	V:[x1] -> [Y1];	Status1.
Status.	Query all output channels current status	V:[x1] -> [Y1];	Status.
Save [H].	Save current state to [H], [Y] is number 0 - 9	<Save to F1!>	Save8.
Recall [H].	Recall [H], [H] is number 0-9	<Recall from F1!>	Recall8.
Clear [H].	Clear data of [H]	<Clear F1!>	Clear8.

FanTemp[H].	Set fan temperature, start fan at [H]	<Set Succeed!>	FanTemp30.
<control/.../>	Control screen ... The instructions to control the big screen, supported maximum bit is 50 bits. In controlling the network, data is forwarded from serial port 0, while date is forwarded from another serial port in controlling the serial port.	<Set Succeed!>	<control/open com0/>
Instructions to acquire board information			
/:ScanPortType;	Scan board slot	<Port/37/In/HDMI/Ver3.1/Ver1.2>	/:ScanPortType;
/:ScanPortResolution;	Scan all input/output boards resolution	<Resolution/37/In/noinput>	/:ScanPortResolution;
\$(X1)ReadInResolution!	Acquire channel [X1] input board resolution	<Resolution/37/In/noinput>	\$(X1)ReadInResolution!
\$(Y1)ReadOutResolution!	Acquire channel [Y1] output board resolution	<Resolution/37/Out/unknown>	\$(Y1)ReadOutResolution!
\$(X1)ReadInType!	Acquire channel [X1] input board type	<Type/37/In/HDMI>	\$(X1)ReadInType!
\$(Y1)ReadOutType!	Acquire channel [Y1] output board type	<Type/37/Out/HDMI>	\$(Y1)ReadOutType!
\$(X1)TemperatureIn!	Acquire channel [X1] input board temperature	<temp/[37,40]/In/24.5>	\$(X1)TemperatureIn!
\$(Y1)TemperatureOut!	Acquire channel [Y1] output board temperature	<temp/[37,40]/Out/24.5>	\$(Y1)TemperatureOut!
AllTemperatureIn!	Analyze all channels input board temperature	<temp/[37,40]/In/24.5> <temp/[65,68]/In/25.5>	AllTemperatureIn!
AllTemperatureOut!	Analyze all channels output board temperature	<temp/[37,40]/Out/24.5> <temp/[61,64]/Out/26.5>	AllTemperatureOut!
AllAnalyseOut!	Analyze all output chips work status		AllAnalyseOut!
AllAnalyseIn!	Analyze all input chips work status		AllAnalyseIn!
\$(X1)AnalyseIn!	Analyze work status of channel [X1] input board chips		\$(X1)AnalyseIn!
\$(Y1)AnalyseOut!	Analyze work status of channel [Y1] output board chips		\$(Y1)AnalyseOut!
Instructions to choose audio infrared serial port			
\$(X1)AudioA!	Select channel [X1] input board analog audio/phoenix infrared serial port input	<Set Succeed!>	\$(X1)AudioA!
\$(X1)AudioD!	Select channel [X1] input board signal audio/network infrared serial port input	<Set Succeed!>	\$(X1)AudioD!
\$(Y1)AudioAOut!	Select channel [Y1] output board infrared serial port phoenix output	<Set Succeed!>	\$(Y1)AudioAOut!
\$(Y1)AudioDOut!	Select channel [Y1] output board infrared serial port output	<Set Succeed!>	\$(Y1)AudioDOut!

EDID management instructions	(in acquiring EDID, EDID data is between <EDID Start/ and /EDID End>. If you want to update or edit EDID on PC, send Update EDID[X1] first to assign a path, then sent updated EDID data, in the end, send UpdateEnd.		
GetInEDID[X1].	Acquire channel [X1] input board EDID (HDMI DVI board effective, is the EDID of current device)	<EDID Start/.../EDID End>	GetInEDID1.
GetOutEDID[Y1].	Acquire channel [Y1] output board EDID (HDMI DVI board effective, is the EDID of current device)	<EDID Start/.../EDID End>	GetOutEDID1.
[Y1]EDIDTo[X1].	Read and output channel [Y1] EDID, and input it to channel [X1] (HDMI DVI board effective)	<Set EDID succeed!>	1EDIDTo1.
UpdateEDID[X1].	Update channel [X1] EDID on PC, (HDMI DVI board effective)	<Update EDID start!>	UpdateEDID1.
UpdateEnd.	Exit update EDID	<Exit Update EDID!>	UpdateEnd.
Instructions to switch audio&video			
[X1]V[Y1].	Channel [X1] input, channel [Y1] output, the audio is switched. When [X1] is 0, it represents closing channel Y1 audio&video	V:[X1] -> [Y1];	1V1.
[X1]v[Y1].	Channel [X1] input, channel [Y1] output, the audio is switched. When [X1] is 0, it represents closing channel Y1 audio&video	v:[X1] -> [Y1];	1v1.
[X1]B[Y1].	Channel [X1] input, channel [Y1] output, the audio is switched. When [X1] is 0, it represents closing channel Y1 audio&video	B:[X1] -> [Y1];	1B1.
[X1]b[Y1].	Channel [X1] input, channel [Y1] output, the audio is switched. When [X1] is 0, it represents closing channel Y1 audio&video	b:[X1] -> [Y1];	1b1.
[X1]V[Y1],[Y2],[Y3]	Channel [X1] input, channel [Y1][Y2][Y3] output	V:[X1] -> [Y1];	1V1,2,3.
[X1]All.	Channel [X1] input, all channels output. When [X1] is 0, it represents closing all channel audio&video	V:[X1] -> [x2];	1All.
All\$.	Close all channels	V:[X1] -> [x2];	All\$.
[X1]\$.	Close channel [X1] output	V:[X1] -> [x2];	1\$.
All#.	Input channels and output channels are mapped respectively.	V:[X1] -> [x2];	All#.
Demo.	The system is set at demo mode. In this mode, each input/output channel will be switched in turn; the time interval is 3 seconds.	<System enter into demo mode!>	Demo.
Instructions to control the network			
<^SPORT>	Query the port number of current matrix network	<SPORT:[X1]>	<^SPORT>
<^SIPR>	Query the IP of current matrix network	<SIPR:[X1].[X2].[X3].[X4]>	<^SIPR>

<^SUBR>	Query the subnet mask of current matrix network	<SUBR:[X1].[X2].[X3].[X4]>	<^SUBR>
<^GAR>	Query the gateway of current matrix network	<GAR:[X1].[X2].[X3].[X4]>	<^GAR>
<^SHAR>	Query hardware address of current matrix network	<SHAR:[X1].[X2].[X3].[X4].[X5].[X6]>	<^SHAR>
<#SPORT[5000]>	Set port number of matrix network(take effect after re-power)	<Set Network Succeed!>	<#SPORT5000>
<#SIPR[192]. [168]. [0]. [2]>	Set IP of matrix network(take effect after re-power)	<Set Network Succeed!>	<#SIPR192. 168. 0. 23>
<#GAR[192]. [168]. [0]. [1]>	Set gateway of of matrix network(take effect after re-power)	<Set Network Succeed!>	<#GAR192. 168. 0. 11>
<#SUBR[255]. [255]. [255]. [0]>	Set subnet mask of matrix network(take effect after re-power)	<Set Network Succeed!>	<#SUBR255. 255. 255. 0>
<#SHAR[00]. [11]. [22]. [33]. [44]. [55]>	Set hardware address(hex) of matrix network(take effect after re-power)	<Set Network Succeed!>	<#SHAR00. 11. 22. 33. 44. 55>
<#NETDEFAULT>	Network configuration restore to factory settings(take effect after re-power)	<Set Network Succeed!>	<#NETDEFAULT>
Instructions to control preview boards			
<^HSSPORT>	Query the port number of preview board network	<HSPORT:[X1]>	<^SPORT>
<^HSSIPR>	Query the IP of preview board network	<HSIPR:[X1].[X2].[X3].[X4]>	<^SIPR>
<^HSSUBR>	Query the subnet mask of preview board network	<HSUBR:[X1].[X2].[X3].[X4]>	<^SUBR>
<^HSGAR>	Query the gateway of preview board network	<HGAR:[X1].[X2].[X3].[X4]>	<^GAR>
<^HSSHAR>	Query hardware address of preview board network	<HSHAR:[X1].[X2].[X3].[X4].[X5].[X6]>	<^SHAR>
<#HSSPORT[5000]>	Set port number of preview board network(take effect after re-power)	<Set Network Succeed!>	<#SPORT[5000]>
<#HSSIPR[192]. [168]. [0]. [2]>	Set IP of preview board network(take effect after re-power)	<Set Network Succeed!>	<#SIPR192. 168. 0. 23>
<#HSGAR [192]. [168]. [0]. [1]>	Set gateway of preview board network(take effect after re-power)	<Set Network Succeed!>	<#GAR192. 168. 0. 11>
<#HSSUBR [255]. [255]. [255]. [0]>	Set subnet mask of preview board network(take effect after re-power)	<Set Network Succeed!>	<#SUBR255. 255. 255. 0>
<#HSSHAR [00]. [11]. [22]. [33]. [44]. [55]>	Set hardware address(hex) of preview board network(take effect after re-power)	<Set Network Succeed!>	<#SHAR0. 11. 22. 33. 44. 55>

<#HSNETDEFAULT>	Network configuration restore to factory settings	<Set Network Succeed!>	<#NETDEFAULT>
<^HSResolution1280*720>	Coding resolution of preview board is set as 1280*720	<Set Succeed!>	<^HSResolution1280*720>
<^HSResolution800*600>	Coding resolution of preview board is set as 800*600	<Set Succeed!>	<^HSResolution800*600>
<^HSResolution640*480>	Coding resolution of preview board is set as 640*480	<Set Succeed!>	<^HSResolution640*480>
<^HSResolution352*288>	Coding resolution of preview board is set as 352*288	<Set Succeed!>	<^HSResolution352*288>
<^HSResolution>	Query current resolution of preview board	<^HSResolution_is_1280*720> or <^HSResolution_is_800*600> or <^HSResolution_is_640*480> or <^HSResolution_is_352*288>	Multicast address is 224.1.1.1---224.1.1.2, the port 0> or <^HSResolution_is_640*480> or <^HSResolution_is_352*288> Port+2, Port+4, Port+6, Port+8 (Port is TCP linking port)

Instructions to switch infrared serial port

[RX1]R[TY1].	Link serial port receiving channel [RX1] of input port to serial port sending channel [TY1] of output port (RS232 forward channel switching)	RS:[RX1]->[TY1];	1R2.
[RY1]S[TX1].	Link serial port receiving channel [RY1] of output port to serial port sending channel [TX1] of input port	TS:[RY1]->[TX1];	1S2.
[RX1]Q[TY1].	Link infrared receiving channel [RX1] of input port to infrared sending channel [TY1] of output port (IR forward channel switching)	IR:[RX1]->[TY1];	1Q2.
[RY1]F[TX1].	Link infrared receiving channel [RY1] of output port to infrared sending channel [TX1] of input port	TR:[RY1]->[TX1];	2F1.
[RX1]T[TY1].	Link serial port/infrared receiving channel [RX1] of input port to serial port/infrared sending channel [TY1] of output port (RS232/IR forward channel switching)	T:[RX1]->[TY1];	1T2.

Instructions to change single output resolution

[\$Y1]->800x600x60Hz!	Channel [Y1] output resolution is 800x600x60Hz (except SDI)	<Set Resolution Succeed!>	!\$1->800x600x60Hz!
[\$Y1]->1024x768x60Hz!	Channel [Y1] output resolution is 1024x768x60Hz (except SDI)	<Set Resolution Succeed!>	!\$1->1024x768x60Hz!
[\$Y1]->1280x720x50Hz!	Channel [Y1] output resolution is 1280x720x60Hz (except SDI)	<Set Resolution Succeed!>	!\$1->1280x720x50Hz!
[\$Y1]->1280x720x60Hz!	Channel [Y1] output resolution is 1280x720x60Hz	<Set Resolution Succeed!>	!\$1->1280x720x60Hz!
[\$Y1]->1280x768x60Hz!	Channel [Y1] output resolution is 1280x768x60Hz (except SDI)	<Set Resolution Succeed!>	!\$1->1280x768x60Hz!
[\$Y1]->1280x800x60Hz!	Channel [Y1] output resolution is 1280x800x60Hz (except SDI)	<Set Resolution Succeed!>	!\$1->1280x800x60Hz!

\$[Y1]->1280x960x60Hz!	Channel [Y1] output resolution is 1280x960x60Hz (except SDI)	<Set Resolution Succeeded!>	\$1->1280x960x60Hz!
\$[Y1]->1280x1024x60Hz!	Channel [Y1] output resolution is 1280x1024x60Hz (except SDI)	<Set Resolution Succeeded!>	\$1->1280x1024x60Hz!
\$[Y1]->1360x768x60Hz!	Channel [Y1] output resolution is 1360x768x60Hz (except SDI)	<Set Resolution Succeeded!>	\$1->1360x768x60Hz!
\$[Y1]->1366x768x60Hz!	Channel [Y1] output resolution is 1366x768x60Hz (except SDI)	<Set Resolution Succeeded!>	\$1->1366x768x60Hz!
\$[Y1]->1440x900x60Hz!	Channel [Y1] output resolution is 1440x900x60Hz (except SDI)	<Set Resolution Succeeded!>	\$1->1440x900x60Hz!
\$[Y1]->1600x900x60Hz!	Channel [Y1] output resolution is 1600x900x60Hz (except SDI)	<Set Resolution Succeeded!>	\$1->1600x900x60Hz!
\$[Y1]->1600x1200x60Hz!	Channel [Y1] output resolution is 1600x1200x60Hz (except SDI)	<Set Resolution Succeeded!>	\$1->1600x1200x60Hz!
\$[Y1]->1920x1080x25Hz!	Channel [Y1] output resolution is 1920x1080x25Hz (SDI HDMI board is valid)	<Set Resolution Succeeded!>	\$1->1920x1080x25Hz!
\$[Y1]->1920x1080x30Hz!	Channel [Y1] output resolution is 1920x1080x30Hz (SDI HDMI board is valid)	<Set Resolution Succeeded!>	\$1->1920x1080x30Hz!
\$[Y1]->1920x1080x50Hz!	Channel [Y1] output resolution is 1920x1080x60Hz	<Set Resolution Succeeded!>	\$1->1920x1080x50Hz!
\$[Y1]->1920x1080x60Hz!	Channel [Y1] output resolution is 1920x1080x60Hz	<Set Resolution Succeeded!>	\$1->1920x1080x60Hz!
\$[Y1]->1920x1200x60Hz!	Channel [Y1] output resolution is 1920x1200x60Hz (except SDI)	<Set Resolution Succeeded!>	\$1->1920x1200x60Hz!
\$[Y1]->1920x540x50Hz!	Channel [Y1] output resolution is 1920x540x50Hz (1920x1080ix50Hz)	<Set Resolution Succeeded!>	\$1->1920x540x50Hz!
\$[Y1]->1920x540x60Hz!	Channel [Y1] output resolution is 1920x540x60Hz (1920x1080ix60Hz)	<Set Resolution Succeeded!>	\$1->1920x540x60Hz!
Instructions to change all output resolution			
\$All->800x600x60Hz!	All channel resolution is 800x600x60Hz(except SDI)	<Set Resolution Succeeded!>	\$All->800x600x60Hz!
\$All->1024x768x60Hz!	All channel resolution is 1024x768x60Hz(except SDI)	<Set Resolution Succeeded!>	\$All->1024x768x60Hz!
\$All->1280x720x50Hz!	All channel resolution is 1280x720x50Hz(except SDI)	<Set Resolution Succeeded!>	\$All->1280x720x50Hz!
\$All->1280x720x60Hz!	All channel resolution is 1280x720x60Hz	<Set Resolution Succeeded!>	\$All->1280x720x60Hz!
\$All->1280x768x60Hz!	All channel resolution is 1280x768x60Hz(except SDI)	<Set Resolution Succeeded!>	\$All->1280x768x60Hz!

\$All->1280x800x60Hz!	All channel resolution is 1280x800x60Hz(except SDI)	<Set Resolution Succeed!>	\$All->1280x800x60Hz!
\$All->1280x960x60Hz!	All channel resolution is 1280x960x60Hz(except SDI)	<Set Resolution Succeed!>	\$All->1280x960x60Hz!
\$All->1280x1024x60Hz!	All channel resolution is 1280x1024x60Hz(except SDI)	<Set Resolution Succeed!>	\$All->1280x1024x60Hz!
\$All->1360x768x60Hz!	All channel resolution is 1360x768x60Hz(except SDI)	<Set Resolution Succeed!>	\$All->1360x768x60Hz!
\$All->1366x768x60Hz!	All channel resolution is 1366x768x60Hz(except SDI)	<Set Resolution Succeed!>	\$All->1366x768x60Hz!
\$All->1440x900x60Hz!	All channel resolution is 1440x900x60Hz(except SDI)	<Set Resolution Succeed!>	\$All->1440x900x60Hz!
\$All->1600x900x60Hz!	All channel resolution is 1600x900x60Hz(except SDI)	<Set Resolution Succeed!>	\$All->1600x900x60Hz!
\$All->1600x1200x60Hz!	All channel resolution is 1600x1200x60Hz(except SDI)	<Set Resolution Succeed!>	\$All->1600x1200x60Hz!
\$All->1920x1080x50Hz!	All channel resolution is 1920x1080x50Hz	<Set Resolution Succeed!>	\$All->1920x1080x50Hz!
\$All->1920x1080x25Hz!	All channel resolution is 1920x1080x25Hz(SDI HDMI is valid)	<Set Resolution Succeed!>	\$All->1920x1080x25Hz!
\$All->1920x1080x30Hz!	All channel resolution is 1920x1080x30Hz(SDI HDMI is valid)	<Set Resolution Succeed!>	\$All->1920x1080x30Hz!
\$All->1920x540x50Hz!	All channel resolution is 1920x540x50Hz(1920x1080ix 50Hz)	<Set Resolution Succeed!>	\$All->1920x540x50Hz!
\$All->1920x1080x60Hz!	All channel resolution is 1920x1080x60Hz	<Set Resolution Succeed!>	\$All->1920x1080x60Hz!
\$All->1920x540x60Hz!	All channel resolution is 1920x540x60Hz(1920x1080ix 60Hz)	<Set Resolution Succeed!>	\$All->1920x540x60Hz!
\$All->1920x1200x60Hz!	All channel resolution is 1920x1200x60Hz(except SDI)	<Set Resolution Succeed!>	\$All->1920x1200x60Hz!
Instructions for VGA output board to output signals			
[\$Y1]VGAOut!	Set channel [Y1] output board as VGA output	<The Port Signal Setting Succeed!>	[\$Y1]VGAOut!
[\$Y1]YUVOut!	Set channel [Y1] output board as YUV output	<The Port Signal Setting Succeed!>	[\$Y1]YUVOut!
Instructions to adjust VGA input/output signals (choose the channel before setting corresponding parameters VGA)			
SetVGAIn[X1].	Set channel [X1] VGA input signal	<Set Succeed!>	SetVGAIn1.
SetVGAOut[Y1].	Set channel [Y1] VGA output signal	<Set Succeed!>	SetVGAOut1.
Bright[H].	Set brightness value of channel [X1] as H (VGA IN/OUT:50)(range from 0 to 100)	<Set Succeed!>	Bright50.

Contrast[H].	Set contrast value of channel [X1] as H (VGA IN/OUT:50)(range from 0 to 100)	<Set Succeed!>	Contrast50.
Saturation[H].	Set saturation value of channel [X1] as H (VGA IN:50)VGA input is valid (range from 0 to 100)	<Set Succeed!>	Saturation50.
Sharp[H].	Set sharp value of channel [X1] as H (VGA IN:50)VGA input is valid (range from 0 to 100)	<Set Succeed!>	Sharp50.
Red[H].	Set Red value of channel [X1] as H (VGA IN:128)VGA input is valid (range from 0 to 255)	<Set Succeed!>	Red128.
Green[H].	Set Green value of channel [X1] as H (VGA IN:128)VGA input is valid (range from 0 to 255)	<Set Succeed!>	Green128.
Blue[H].	Set Blue value of channel [X1] as H (VGA IN:128)VGA input is valid (range from 0 to 255)	<Set Succeed!>	Blue128.
AutoConfig.	Set channel [X1] automatic adjustment (VGA input is valid)	<Set Succeed!>	AutoConfig.
HPosUp.	Set channel [X1] horizontal position +1 (VGA input is valid)	<Set Succeed!>	HPosUp.
HPosDown.	Set channel [X1] horizontal position -1 (VGA input is valid)	<Set Succeed!>	HPosDown.
VPosUp.	Set channel [X1] vertical position +1 (VGA input is valid)	<Set Succeed!>	VPosUp.
VPosDown.	Set channel [X1] vertical position -1 (VGA input is valid)	<Set Succeed!>	VPosDown.
HSizeUp.	Set channel [X1] horizontal size +1 (VGA input is valid)	<Set Succeed!>	HSizeUp.
HSizeDown.	Set channel [X1] horizontal size -1 (VGA input is valid)	<Set Succeed!>	HSizeDown.
VSizeUp.	Set channel [X1] vertical size +1 (VGA input is valid)	<Set Succeed!>	VSizeUp.
VSizeDown.	Set channel [X1] vertical size -1 (VGA input is valid)	<Set Succeed!>	VSizeDown.
PosReset.	Set channel [X1] video position reset (VGA input is valid)	<Set Succeed!>	PosReset.

4.2 Splicer instructions

instructions (pc-->controller)	Functions	Returned information
[X]M[W], [Y].	Switch input channel no. [X] to videowall no. [W] (Wall no.1~5) on window ID.Y (You can check the window ID no. on the PC software, when you set the window ID no. according to the order from left to right and from up to down to increase the window ID from no. 1 to no. N ,then it will be easy to know the window ID without checking the software.) For example switch input no.1 to videowall no.2 on its window ID no.3 with command 1M2,3.	1M2,3.
SavePJ[X], [Y].	Save the current profile [X]:videowall no.1 to 5 [Y]:Save to the profile position no.0 to 11 Example. SavePJ1,10.	SavePJ1,10.

RecallPJ[X], [Y].	Recall the saved profile [X]:videowall no.1 to 5 [Y]:Save to the profile position no.0 to 11 Example RecallPJ1,10.	RecallPJ1,10.
ClearPJ[X], [Y].	Clear the saved profile [X]:videowall no.1 to 5 [Y]:Save to the profile position no.0 to 11 Example ClearPJ1,10.	ClearPJ1,10.
<#MARGIN[X1],[x1]>	Screen spacing of video wall: [X1]: video wall identification [x1]: screen spacing	<Set Succeed!>
<#MAP[X1],[x1],[x2]>	Window x1 of video wall x mapped to output port x2	<Set Succeed!>
<#SIZE[X1],[x1],[x2]>	Window size of PC: [X1]: video wall identification [x1]: horizontal size [x2]: vertical size	<Set Succeed!>
<#VIR[X1],[x1],[x2]>	Window array of PC: [X1]: video wall identification [x1]: number of horizontal windows [x2]: number of vertical windows	<Set Succeed!>
<#OPEN[X1],[x1],[x2],[x3],[x4],[x5],[x6],[x7]>	Setting parameters of opening new windows: [X1]: video wall identification [x1]: window identification [x2]: input source [x3]: layer number [x4]: window horizontal position [x5]: window vertical position [x6]: window horizontal length [x7]: window vertical length	<Set Succeed!>
<#MOVE[X1],[x1],[x2],[x3]>	Setting parameters of moving windows: [X1]: video wall identification [x1]: window identification [x2]: window horizontal position [x3]: window vertical position	<Set Succeed!>
<#RESIZE[X1],[x1],[x2],[x3],[x4],[x5]>	Setting parameters of stretching windows: [X1]: video wall identification [x1]: window identification [x2]: window horizontal position [x3]: window vertical position [x4]: window horizontal size [x5]: window vertical size	<Set Succeed!>
<#LAYER[X1],[x1],[x2]>	Setting parameters of window layers:[X1]:video wall identification [x1]: window identification [x2]: layer number	<Set Succeed!>
<#CLOSE[X1],[x1]>	Window closing setting: [X1]: video wall identification [x1]: window identification	<Set Succeed!>
<^JOINT>	Query spicing state of all video walls	<OPEN[X1],[x1],[x2],[x3],[x4],[x5],[x6],[x7]>
<^SIZE>	Query window size of PC	<SIZE[X1],[x1],[x2]>
<^VIR>	Query window array of PC	<VIR[X1],[x1],[x2]>
<^MAP>	Query mapping relation	<MAP[X1],[x1],[x2]>
<^MARGIN>	Query the setting parameters of screen pitch	<MARGIN[X1],[x1]>